

STEGE SANITARY DISTRICT BOARD OF DIRECTORS
MEETING OF NOVEMBER 10, 2022
TIME OF MEETING: 7:00 P.M.
DISTRICT BOARD ROOM, 7500 SCHMIDT LANE, EL CERRITO, CA

***** AGENDA *****

Items on the agenda may be taken out of order.

Public comment is limited to three (3) minutes for each individual speaker.

In accordance with California Government Code Section 54957.5, any writing that is a public record and relates to an open session agenda item which is distributed less than 72 hours prior to the meeting shall be available for public inspection at the District Office, 7500 Schmidt Lane, El Cerrito, during regular business hours. Copies of the agenda are posted on the District website at www.stegesan.org Those disabled persons requiring auxiliary aids or services in attending or participating in this meeting should notify the District at least 48 hours prior to the meeting at 510/524-4668.

Members of the public can observe the live stream of the meeting by accessing <https://zoom.us/j/84090509848> or by calling (669) 900-9128 and entering the Meeting ID# 840 9050 9848 followed by the pound (#) key.

Public comment can be sent remotely by delivering to 7500 Schmidt Lane, El Cerrito, CA 94530 or via email to comments@stegesan.org with "Public Comment" in the subject line. To provide written comment on an item on the agenda or to address the Board during Public Comment, please note the agenda item number that you want to address or whether you intend for the comment to be included in Public Comment. Comments timely received 15 minutes before the starting time of the meeting will either be provided as written comment or be read into the record, with a maximum allowance of 3 minutes per individual comment read into the record, subject to the Board President's discretion. Copies of all timely received written comments will be provided to the Board and will be added to the official record.

Pursuant to AB 361, Board Members may be attending this meeting via remote conferencing. In the event that any Board Member elects to attend remotely, all votes conducted during the remote conferencing session will be conducted by roll call vote.

I. Call To Order

II. Roll Call

Agenda Items: Directors and Officers of the Board will consider and announce if they have any conflicts of interest posed by items on the meeting agenda.

III. Public Comment

(Members of the public are invited to address the Board concerning topics that are **not** on the agenda)

STEGE SANITARY DISTRICT BOARD OF DIRECTORS
MEETING OF NOVEMBER 10, 2022
TIME OF MEETING: 7:00 P.M.
DISTRICT BOARD ROOM, 7500 SCHMIDT LANE, EL CERRITO, CA

IV. Approval of Minutes

- Motion: A. Approval of October 20, 2022 Board Meeting Minutes
(The Board will be asked to review and approve the minutes)

Info: **V. Communications**

- A. Oral Communications
1. Brief reports from Directors on matters related to the District, including attendance at city or community meetings
 - a. City & Community Meetings
- B. Written Communications

Info: **VI. Reports of Staff and Officers**

- A. Attorney's Report:
- B. Manager's Report:
1. Monthly Maintenance Summary Report
 2. Monthly Report of Sewer Replacements and Repairs
 3. Proposed Meeting Calendar
 4. Board Officer Succession Plan
 5. 2023 California Association of Sanitation Agencies (CASA) Conferences
 - January 25-27 – Winter Conference, Palm Springs, CA
 - February 27 - March 1 – Washington DC Forum
 - August 9-11 – Annual Conference, San Diego, CA
 6. 2023 California Special Districts Association (CSDA) Conference
 - August 28-31 – Annual Conference, Monterey, CA

VII. Business

- Ordinance/Motion: A. Ordinance No. 2213-1122 Amending the Stege Sanitary District Ordinance Code, Section 4.8.2.2 - Lateral Replacement Loan Program
(The Board will review and consider the Ordinance)

- Ordinance/Motion: B. Ordinance No. 2214-1122 Amending the Stege Sanitary District Ordinance Code, Section 4.4.5 – Backflow Protective Device
(The Board will review and consider the Ordinance)

STEGE SANITARY DISTRICT BOARD OF DIRECTORS
MEETING OF NOVEMBER 10, 2022
TIME OF MEETING: 7:00 P.M.
DISTRICT BOARD ROOM, 7500 SCHMIDT LANE, EL CERRITO, CA

- Resolution/Motion: C. Resolution No. 2215-1122 Finding that there is a Proclaimed State of Emergency; Finding that Meeting in Person Would Present Imminent Risks to the Health or Safety of Attendees as a Result of the State of Emergency; and Authorizing Remote Teleconferenced Meetings of the Stege Sanitary District for the 30 Day Period Beginning November 10 Pursuant to AB 361
(The Board will review and consider the resolution to continue to meet remotely pursuant to Assembly Bill 361)
- Resolution/Motion: D. Resolution No. 2216-1122 Approving a Contract with WECO Industries, LLC for a 2023 GapVax MC1007-3S3X Combination Water Jetting and Vacuum System Sewer Cleaning Truck in the Amount Not to Exceed \$559,281.43
(The Board will review and consider the resolution)
- Resolution/Motion: E. Resolution No. 2217-1122 Commending Alan C. Miller for the Long and Extraordinary Service as a Member of the Board of Directors of the Stege Sanitary District
(The Board will review and consider the resolution)
- Info/Motion: F. Consideration of Relocation of Sanitary Sewer Main – 1755 Eastshore Blvd., El Cerrito, CA 94530
(The Board will review and consider the request)

Info: **VIII. Monthly Financial Statements**

- A. Monthly Investment, Cash, Receivables Report
B. Monthly Operating Statement
(The Board will review the reports and statements)

IX. Approval of Checks

- Info/Motion: A. Checks for November 10, 2022 - Fund No. 3418 & 3423
(The Board will be asked to consider approval of the November checks)

Info: **X. Future Agenda Items**

December 8, 2022 – 2:00PM

- Fiscal Year Financial Audit
Connection Charge Review
Emergency Contact Update

STEGE SANITARY DISTRICT BOARD OF DIRECTORS
MEETING OF NOVEMBER 10, 2022
TIME OF MEETING: 7:00 P.M.
DISTRICT BOARD ROOM, 7500 SCHMIDT LANE, EL CERRITO, CA

Meeting Calendar
Consent Decree Quarterly Report
CASA Conference
Pension + OPEB UAL Reports
Nomination & Election of Officers
+AB 361 – 30 Day Virtual Meeting Extension

January 19, 2023

CLOSED SESSION – Quarterly Claims Reports
CLOSED SESSION – Manager Performance Evaluation
Board Governance Manual Review
Service Rate Discussion
Long Range Planning Workshop Agenda
Director’s Contact Info
Board Training Summary
CASA Conference
Quarterly Financial Statements
Form 700
+AB 361 – 30 Day Virtual Meeting Extension

CLOSED SESSION

Public Employment Performance Evaluation

Gov. Code § 54957
Title: District Manager

XI. Adjournment

(The next meeting of the Stege Sanitary District Board of Directors is scheduled to be held on December 8, 2022 at 2:00 P.M. at the District Board Room, 7500 Schmidt Lane, El Cerrito, California.)

STEGE SANITARY DISTRICT BOARD OF DIRECTORS
 MEETING OF OCTOBER 20, 2022
 TIME OF MEETING: 7:00 P.M.
 DISTRICT BOARD ROOM, 7500 SCHMIDT LANE, EL CERRITO, CA

*****MINUTES*****

- I. Call To Order:** President Merrill called the meeting to order at 7:00 P.M.
- II. Roll Call:** Present: Miller*, O'Keefe*, Merrill
 Absent: Christian-Smith (gave prior notice), Gilbert-Snyder
 (gave prior notice)
 Others Present: Rex Delizo, District Manager
 Kristopher Kokotaylo, District Counsel
**via video-conference*

Agenda Items: Directors and Officers of the Board did not announce any conflicts of interest posed by items on the meeting agenda.

III. Public Comment: Miller commented that since he volunteers at the Christ Lutheran Senior Center farmer's market on Mondays, he arranged for the District Manager to give a talk regarding laterals at a concurrent meeting for the Christ Lutheran Senior Center. There was no other public comment.

IV. Approval of Minutes

A. Approval of October 6, 2022 Board Meeting Minutes

MOTION: By O'Keefe, seconded by Miller, to approve the minutes of the October 6, 2022 Board Meeting

VOTE: AYES: Miller, O'Keefe, Merrill
 NOES: None
 ABSTAIN: None
 ABSENT: Christian-Smith, Gilbert-Snyder

V. Communications

A. Oral Communications

STEGE SANITARY DISTRICT BOARD OF DIRECTORS
MEETING OF OCTOBER 20, 2022
TIME OF MEETING: 7:00 P.M.
DISTRICT BOARD ROOM, 7500 SCHMIDT LANE, EL CERRITO, CA

1. Brief reports from Directors on matters related to the District, including attendance at city or community meetings

a. City & Community Meetings

Director Miller gave a report of his review of the agenda of a recent El Cerrito City Council Meeting.

B. Written Communications

There were no written communication items to consider.

VI. Reports of Staff and Officers

A. Attorney's Report

Kokotaylo reported that Governor Newsom announced the COVID-19-related state of emergency would come to an end on February 28, 2023. With the state of emergency ending, initiatives relying on the active state of emergency would cease to remain in effect including remote meetings that use the framework enacted by the passage of Assembly Bill 361 (R. Rivas, 2021). Kokotaylo then reported on Senate Bill 1439 that amends California Government Code Section 84308 to no longer exclude local government agencies whose members are directly elected by the voters from accepting contributions of over \$250 from contractors.

B. Manager's Report

1. Monthly Maintenance Summary Report

The Manager reported no significant issues on last month's maintenance activities.

2. Monthly Report of Sewer Replacements and Repairs

The Manager reported on the invoices paid in September.

3. San Pablo Avenue Specific Plan Area (SPASPA) Status Report

The Manager reported on the status of the SPASPA impact fee.

4. Draft Endeavor Newsletter

The Manager reported on the draft of the upcoming newsletter.

5. 2023 California Association of Sanitation Agencies (CASA) Conferences

The Manager reported on the upcoming CASA conferences dates for 2023.

STEGE SANITARY DISTRICT BOARD OF DIRECTORS
MEETING OF OCTOBER 20, 2022
TIME OF MEETING: 7:00 P.M.
DISTRICT BOARD ROOM, 7500 SCHMIDT LANE, EL CERRITO, CA

6. 2023 California Special Districts Association (CSDA) Conference
The Manager reported on the upcoming CSDA annual conference date for 2023.

VII. Business

A. Resolution No. 2211-1022 to Oppose Initiative 21-0042A1

The Board considered a resolution opposing Initiative 21-0042A1 which limits the ability of voters and state and local governments to raise revenue for government services.

MOTION: By Miller, seconded by O'Keefe, to approve Resolution No. 2211-1022 to Oppose Initiative 21-0042A1

VOTE: AYES: Miller, O'Keefe, Merrill
NOES: None
ABSTAIN: None
ABSENT: Christian-Smith, Gilbert-Snyder

B. Resolution No. 2212-1022 Finding that there is a Proclaimed State of Emergency; Finding that Meeting in Person Would Present Imminent Risks to the Health or Safety of Attendees as a Result of the State of Emergency; and Authorizing Remote Teleconferenced Meetings of the Stege Sanitary District for the 30 Day Period Beginning October 20 Pursuant to AB 361

The Board approved the resolution to make necessary findings to continue to meet remotely pursuant to Assembly Bill 361.

MOTION: By O'Keefe, seconded by Miller, to approve Resolution No. 2212-1022 Finding that there is a Proclaimed State of Emergency; Finding that Meeting in Person Would Present Imminent Risks to the Health or Safety of Attendees as a Result of the State of Emergency; and Authorizing Remote Teleconferenced Meetings of the Stege Sanitary District for the 30 Day Period Beginning October 20 Pursuant to AB 361

STEGE SANITARY DISTRICT BOARD OF DIRECTORS
MEETING OF OCTOBER 20, 2022
TIME OF MEETING: 7:00 P.M.
DISTRICT BOARD ROOM, 7500 SCHMIDT LANE, EL CERRITO, CA

VOTE: AYES: Miller, O’Keefe
NOES: Merrill
ABSTAIN: None
ABSENT: Christian-Smith, Gilbert-Snyder

NOTE: Per the Stege Sanitary District Ordinance Code, basic approval of a Board action, unless otherwise stated in relevant federal or state laws, rules or regulations, is by “majority vote” defined as more than half of the Board Members present at the meeting.

C. Ordinance No. 2213-1022 Amending the Stege Sanitary District Ordinance Code, Section 4.8.2.2 - Lateral Replacement Loan Program

The Board considered an ordinance that would exclude properties that trigger the regional PSL ordinance from participating in the program, but tabled the discussion, by unanimous consent, to the following Board meeting.

D. Ordinance No. 2214-1022 Amending the Stege Sanitary District Ordinance Code, Section 4.4.5 – Backflow Protective Device

The Board considered an ordinance that would require BPDs for all properties regardless of the elevation difference of the next upstream manhole, but tabled the discussion, by unanimous consent, to the following Board meeting.

VIII. Monthly Financial Statements - September 2022

- A. Monthly Investment, Cash, Receivables Report
- B. Monthly Operating Statement
- C. Cash on Hand vs. Target Reserves
- D. Local Agency Investment Fund (LAIF) Quarterly Statement
- E. California Employer’s Retiree Benefit Trust (CERBT) Quarterly Statement

The financial items were reviewed by the Board with no significant issues.

IX. Approval of Checks

- A. Checks for October 20, 2022 - Fund No. 3418 & 3423

STEGE SANITARY DISTRICT BOARD OF DIRECTORS
 MEETING OF OCTOBER 20, 2022
 TIME OF MEETING: 7:00 P.M.
 DISTRICT BOARD ROOM, 7500 SCHMIDT LANE, EL CERRITO, CA

MOTION: By O’Keefe, seconded by Miller, to pay the bills, Check Nos. 27869 through 27893 in the amount of \$124,525.89

VOTE: AYES: Miller, O’Keefe, Merrill
 NOES: None
 ABSTAIN: None
 ABSENT: Christian-Smith, Gilbert-Snyder,

X. Future Agenda Items

November 10, 2022

Proposed Meeting Calendar
 Board Officer Succession Plan
 CASA Conference
 +AB 361 – 30 Day Virtual Meeting Extension

December 8, 2022 – 2:00PM

Fiscal Year Financial Audit
 Connection Charge Review
 Emergency Contact Update
 Meeting Calendar
 Consent Decree Quarterly Report
 CASA Conference
 Pension + OPEB UAL Reports
 Nomination & Election of Officers
 +AB 361 – 30 Day Virtual Meeting Extension

CLOSED SESSION

Conference with Legal Counsel—Anticipated Litigation

Significant exposure to litigation pursuant to paragraph (2) of subdivision (d) of Section 54956.9

Number of Potential Cases: 2

STEGE SANITARY DISTRICT BOARD OF DIRECTORS
MEETING OF OCTOBER 20, 2022
TIME OF MEETING: 7:00 P.M.
DISTRICT BOARD ROOM, 7500 SCHMIDT LANE, EL CERRITO, CA

Shimoni – Government Tort Claim filed: 10/25/2021

Troy – Government Tort Claim filed: 5/2/2022

Public Employment Performance Evaluation

Gov. Code § 54957

Title: District Manager

The Board entered into closed session at 8:03 P.M. and returned to open session at 8:07 P.M. President Merrill announced the Board had taken no reportable actions.

XI. Adjournment

The meeting was adjourned at 8:07 P.M. The next meeting of the District Board of Directors will be held on Thursday, November 10, 2022 at 7:00 P.M. at the District Board Room, 7500 Schmidt Lane, El Cerrito, California

Rex Delizo
STEGE SANITARY DISTRICT
Secretary

STEGE SANITARY DISTRICT
MONTHLY MAINTENANCE SUMMARY REPORT
Oct-22

1. ROUTINE PREVENTIVE MAINTENANCE ACTIVITIES

There were 21 normal working days		Days	Feet
Unit #10 (combo) operated:		14	98,370
Unit #11 (rodder) operated:		0	0
Unit #15 (video) operated:		12	18,187
Unit #16 (combo) operated:		11	19,554

	Month (feet)		Quarter (feet)		
	Planned	Unplanned	Planned	Unplanned	Remaining
Total Cleaned	62,515	55,409	62,515	55,409	141,225
Total Video	8,244	9,943	8,244	9,943	56,782

2. MONTHLY SERVICE CALLS

After-hour service calls: 0 Calls 0 Calls

SERVICE CALLS, OVERFLOWS, AND BACKUPS

YEAR	MO	SERVICE CALLS		LATERAL PROBLEMS		STRUCTURAL MAINLINE FAILURES		MAINLINE OVERFLOWS INTO HOMES	
		CURRENT MONTH	12 MONTH AVERAGE	CURRENT MONTH	12 MONTH AVERAGE	CURRENT MONTH	TOTAL LAST 12-MOS	CURRENT MONTH	TOTAL LAST 12-MOS
2022	10	11	14.0	6	7.3	0	3	0	0
CATEGORY 1 SSOs		OVERFLOWS CAUSED BY MAINLINE				OVERFLOWS RELATED TO WET WEATHER			
CURRENT MONTH	TOTAL LAST 12-MONTHS	CURRENT MONTH	TOTAL LAST 12-MONTHS	CURRENT MONTH	TOTAL LAST 12-MONTHS	CURRENT MONTH	TOTAL LAST 12-MONTHS	CURRENT MONTH	TOTAL LAST 12-MONTHS
0	0	0	8	0	0	0	0	0	0

3. SAFETY AND TRAINING

Safety and training meetings were conducted twice a month.

MONTHLY SERVICE CALLS

October-2022

DATE	MH UP/DN	ADDRESS	PRBLM IN	TYPE	LOC	CAUSE	END	COMMENTS
10/7/2022 Friday 3:45 PM	272513 272503	271 LAKE DR. KENSINGTON, CA 94707	Main <input type="checkbox"/> Lateral <input checked="" type="checkbox"/> Other <input type="checkbox"/>	C, LC				WE FOUND THE CLOGGED TOILET TO BE THE CUSTOMER'S PROBLEM.
10/10/2022 Monday 1:05 PM	187207 18705	5709 ALTA PUNTA AVE. EL CERRITO, CA 94530	Main <input type="checkbox"/> Lateral <input checked="" type="checkbox"/> Other <input type="checkbox"/>	C				WE FOUND THIS TO BE THE CUSTOMER'S PROBLEM.
10/10/2022 Monday 4:15 PM	281202 281201	931 ELM ST. EL CERRITO, CA 94530 <i>Last Call: 3/4/2022</i>	Main <input type="checkbox"/> Lateral <input checked="" type="checkbox"/> Other <input type="checkbox"/>	C, LC				WE FOUND THE PROBLEM IN CUSTOMER'S LATERAL.
10/13/2022 Thursday 2:12 PM	163013 163012	11100 SAN PABLO AVE. EL CERRITO, CA 94530	Main <input type="checkbox"/> Lateral <input checked="" type="checkbox"/> Other <input type="checkbox"/>	C				WE FOUND THIS TO BE THE CUSTOMER'S PROBLEM.
10/17/2022 Monday 8:18 AM	266103 266003	851 GALVIN DR. EL CERRITO, CA 94530	Main <input type="checkbox"/> Lateral <input type="checkbox"/> Other <input checked="" type="checkbox"/>	T				CUSTOMER'S BPD WAS BLOWN OFF BY OUR HYDRO JET.
10/17/2022 Monday 10:47 AM	251237 251236	611 BONNIE DR. EL CERRITO, CA 94530	Main <input type="checkbox"/> Lateral <input checked="" type="checkbox"/> Other <input type="checkbox"/>	C				WE FOUND THIS TO BE THE CUSTOMER'S PROBLEM.
10/17/2022 Monday 1:39 PM	142204 14007	1220 ELM ST. EL CERRITO, CA 94530	Main <input type="checkbox"/> Lateral <input type="checkbox"/> Other <input checked="" type="checkbox"/>	T				THE SINK HOLE ISN'T THE DISTRICTS PROBLEM.
10/18/2022 Tuesday 2:00 PM	212122 212121	2817 SANTA CLARA ST. RICHMOND, CA 94804 <i>Last Call: 4/13/2002</i>	Main <input type="checkbox"/> Lateral <input type="checkbox"/> Other <input checked="" type="checkbox"/>	T				WE FOUND THE DEAD PLANT NEAR MANHOLE TO BE THE CUSTOMER'S PROBLEM.
10/19/2022 Wednesday 1:55 PM	731021 231026	550 COVENTRY RD. KENSINGTON, CA 94707	Main <input type="checkbox"/> Lateral <input type="checkbox"/> Other <input checked="" type="checkbox"/>	O				HOUSE ADDRESS WAS NOT CORRECT CALLED THE NUMBER NO ANSWER, CHECKED MANHOLES, NO SMELL
10/27/2022 Thursday 8:00 AM	171012 071010	7234 BLAKE ST. EL CERRITO, CA 94530	Main <input type="checkbox"/> Lateral <input checked="" type="checkbox"/> Other <input type="checkbox"/>	C, LC				WE FOUND THIS TO BE THE CUSTOMER'S PROBLEM.
10/31/2022 Monday 2:41 PM	161804 162013	1520 ELM ST. EL CERRITO, CA 94530	Main <input type="checkbox"/> Lateral <input type="checkbox"/> Other <input checked="" type="checkbox"/>	T				WE FOUND THIS TO BE THE CUSTOMER'S PROBLEM. NOISY TOILET

PROBLEM TYPE:

Water (A) Odor (O)
 Broken Main (B) Overflow (OF)
 S/S Congestion (C) PG+E (P)
 Debris in Main (D) Roots (R)
 EBMUD (E) Surcharge (S)
 Soft Stoppage (F) Storm Drain (SD)
 Grease (G) Unknown (U)
 Lateral Cause (LC) Other (T)
 Misc (M) Wipes/Rags (W)
 MH Cover (MC)

SPILL

LOCATION:
 Lamp/Manhole (MH)
 Mainline (ML)
 Lateral (L)
 Cleanout (CO)
 Building (BLDG)
 Other (O)

SPILL

CAUSE:
 Blockage (B)
 Surcharge (S)
 Line Break (ML)
 Other (O)

SPILL END

LOCATION:
 Building (BLDG)
 Creek (C)
 Strt/Pvmnt (ST)
 Storm Drn (SD)
 Yard (Y)
 Other (O)

MAINLINE:	0
LATERAL:	6
OTHER:	5
TOTAL SERVICE CALLS:	11
MAINLINE OVERFLOW:	0
MAINLINE SURCHARGE:	0

SANITARY SEWER OVERFLOWS (SSOs) LAST 12 MONTHS

November-2022

DATE	MH UP/DN	ADDRESS	PRBLM IN	TYPE	LOC	CAUSE	END	COMMENTS	CAT*	VOL	RCVR'D	NET
12/30/2021 Thursday 10:10 AM	271120 271119	422 COLUSA AVE. EL CERRITO, CA 94530	Main <input checked="" type="checkbox"/> Lateral <input type="checkbox"/> Other <input type="checkbox"/>	F, R	MH	B	ST, Y	ROOT IN LINE CAUSED SSO	CAT 3	205 gallons	140 gallons	65 gallons
1/17/2022 Monday 5:58 PM	187218 187210	5619 JORDAN AVE. EL CERRITO, CA 94530	Main <input checked="" type="checkbox"/> Lateral <input type="checkbox"/> Other <input type="checkbox"/>	B, E,OF	CO	ML, B	Y	EBMUD DAMAGED OUR LINE WHILE WORKING IN THE STREET.	CAT 3	25 gallons	0 gallons	25 gallons
1/29/2022 Saturday 3:25 PM	231822 231819	616 PLATEAU DR. KENSINGTON, CA 94707	Main <input checked="" type="checkbox"/> Lateral <input type="checkbox"/> Other <input type="checkbox"/>	B, OF,R, W	LH	ML, B	Y	SSO CAUSED BY MAJOR OFFSET.	CAT 3	15 gallons	0 gallons	15 gallons
2/3/2022 Thursday 7:30 AM	151239 151238	1373 CONTRA COSTA DR. EL CERRITO, CA 94530	Main <input checked="" type="checkbox"/> Lateral <input type="checkbox"/> Other <input type="checkbox"/>	R	MH	B	Y	CITY OF EL CERRITO PUSHED LATERAL ROOTS INTO DISTRICT LINE.	CAT 3	23 gallons	23 gallons	0 gallons
3/26/2022 Saturday 6:50 PM	251414 251403	7976 TERRACE DR. EL CERRITO, CA 94530	Main <input checked="" type="checkbox"/> Lateral <input type="checkbox"/> Other <input type="checkbox"/>	OF	MH	ML	Y	SSO CAUSED BY COLAPSED HDPE PIPE.	CAT 2	3,432 gallons	0 gallons	3,432 gallons
5/7/2022 Saturday 1:30 PM	292102 292004	1126 RICHMOND ST. EL CERRITO, CA 94530	Main <input checked="" type="checkbox"/> Lateral <input type="checkbox"/> Other <input type="checkbox"/>	OF, R	MH	B	ST	SOFT STOPPAGE IN MAIN LINE. FOUND ROOTS AND RAGS IN LINE.	CAT 3	1 gallons	1 gallons	0 gallons
6/8/2022 Wednesday 9:54 AM	282319 220026	6831 STOCKTON AVE. EL CERRITO, CA 94530	Main <input checked="" type="checkbox"/> Lateral <input type="checkbox"/> Other <input type="checkbox"/>	D, E	CO	B	ST,SD,Y	EBMUD DAMAGED LAMPHOLE #282318 AND FILLED WITH ASPHALT.	CAT 3	80 gallons	80 gallons	0 gallons
8/8/2022 Monday 11:30 PM	273103 273001	27 SUNSET DR. KENSINGTON, CA 94707	Main <input checked="" type="checkbox"/> Lateral <input type="checkbox"/> Other <input type="checkbox"/>	LC, R	BLDG	B	BLDG/ST	LATERAL ROOT CAUSED SSO.	CAT 3	15 gallons	10 gallons	5 gallons

PROBLEM TYPE:

Water (A)
Broken Main (B)
S/S Congestion (C)
Debris in Main (D)
EBMUD (E)
Soft Stoppage (F)
Grease (G)
Lateral Cause (LC)
Misc (M)
MH Cover (MC)

Odor (O)
Overflow (OF)
PG+E (P)
Roots (R)
Surcharge (S)
Storm Drain (SD)
Unknown (U)
Other (T)
Wipes/Rags (W)

SPILL

LOCATION:
Lamp/Manhole (MH)
Mainline (ML)
Lateral (L)
Cleanout (CO)
Building (BLDG)
Other (O)

SPILL

CAUSE:
Blockage (B)
Surcharge (S)
Line Break (ML)
Other (O)

SPILL END

LOCATION:
Building (BLDG)
Creek (C)
Strt/Pvmnt (ST)
Storm Drn (SD)
Yard (Y)
Other (O)

TOTAL MAINLINE SSOs: 8
MAINLINE BREAK SSOs: 3
MAINLINE SURCHARGE SSOs: 0
CATEGORY 1 SSOs: 0
SSOs INTO BUILDINGS: 1

TOTAL SSO VOLUME (GALS): 3,796
TOTAL VOLUME RECOVERED (GALS): 254
TOTAL VOLUME UNRECOVERED (GALS): 3,542

DATE	MH UP/DN	ADDRESS	PRBLM IN	TYPE	LOC	CAUSE	END	COMMENTS	CAT*	VOL	RCVR'D	NET
------	----------	---------	----------	------	-----	-------	-----	----------	------	-----	--------	-----

*CATEGORY 1 SSO: Discharges of untreated or partially treated wastewater of any volume resulting from an enrollees sanitary sewer system failure or flow condition that: Reach surface water and/or reach a drainage channel tributary to a surface water; or Reach a municipal separate storm sewer system and are not fully captured and returned to the sanitary sewer system or not otherwise captured and disposed of properly. Any volume of wastewater not recovered from the municipal separate storm sewer system is considered to have reached surface water unless the storm drain system discharges to a dedicated storm water or ground water infiltration basin (e.g., infiltration pit, percolation pond).

CATEGORY 2 SSO: Discharges of untreated or partially treated wastewater of 1,000 gallons or greater resulting from an enrollee's sanitary sewer system failure or flow condition that do not reach surface water, a drainage channel, or a municipal separate storm sewer system unless the entire SSO discharged to the storm drain system is fully recovered and disposed of properly.

CATEGORY 3 SSO: All other discharges of untreated or partially treated wastewater resulting from an enrollees sanitary sewer system failure or flow condition.

**STEGE SANITARY DISTRICT
MONTHLY REPLACEMENT AND REPAIR SUMMARY
October 2022**

I SEWER REPLACEMENT - FY 2022-2023			
A.	BUDGET ALLOCATION		\$3,259,000
B.	PRIOR BUDGET EXPENDED (WITH RETENTION)		\$0
C.	SEWER REPLACEMENTS PAID THIS MONTH (NO RETENTION)		
SUBTOTAL FOR THIS MONTH			\$0
D.	TOTAL BUDGET EXPENDED (NO RETENTION)	0.00%	\$0
E.	TOTAL 5% RETENTION HELD		\$0
F.	BUDGET REMAINING	100.00%	\$3,259,000
G.	PERCENTAGE OF FISCAL YEAR REMAINING	66.67%	
H.	TOTAL REPLACEMENT FOOTAGE PAID TO DATE	0 (\$ - /LF)	

II SEWER REPAIRS - FY 2022-2023			
A.	BUDGET ALLOCATION		\$70,000
B.	PRIOR BUDGET EXPENDED		\$18,980
C.	SEWER REPAIRS PAID THIS MONTH	<u>REPAIR COST</u>	
	1 5523 Colusa	\$2,900	
SUBTOTAL FOR THIS MONTH			\$2,900
SUBTOTAL FOR LAST MONTH			\$18,980
D.	TOTAL BUDGET EXPENDED	31.26%	\$21,880
E.	TOTAL RETENTION HELD	0.00%	\$0
F.	BUDGET REMAINING	68.74%	\$48,120
G.	PERCENTAGE OF FISCAL YEAR REMAINING	66.67%	
H.	TOTAL NUMBER OF REPAIRS PAID TO DATE	3 (\$7,293 /REPAIR)	

**STEGE SANITARY DISTRICT
MONTHLY REPLACEMENT AND REPAIR SUMMARY
October 2022**

III SAN PABLO AVE SPECIFIC PLAN AREA (SPASPA) UPGRADE - FY 2022-2023			
A.	BUDGET ALLOCATION		\$0
B.	PRIOR BUDGET EXPENDED (WITH RETENTION)		\$0
C.	SPASPA UPGRADES PAID THIS MONTH (NO RETENTION)		
SUBTOTAL FOR THIS MONTH			\$0
D.	TOTAL BUDGET EXPENDED (NO RETENTION)	0.00%	\$0
E.	TOTAL 5% RETENTION HELD	0.00%	\$0
F.	BUDGET REMAINING	100.00%	\$0
G.	PERCENTAGE OF FISCAL YEAR REMAINING	66.67%	
H.	TOTAL SPASPA UPGRADE FOOTAGE PAID TO DATE	0 (\$ - /LF)	

STEGE SANITARY DISTRICT

2023 BOARD MEETING SCHEDULE

(Start time is 7PM unless stated otherwise)

January 19

February 2
February 16

March 4 @9am (LRP*)
March 16

April 6
April 20

May 4
May 18

June 1
June 15

July 6
July 20

August 17

September 7
September 21

October 5
October 19

November 9

December 7 @2pm

** Long Range Planning – All Day Workshop*

DRAFT 2023 Stege Sanitary District Board Meeting Schedule

JANUARY						
S	M	T	W	T	F	S
1	2	3	4	5	6	7
8	9	10	11	12	13	14
15	16	17	18	19	20	21
22	23	24	25	26	27	28
29	30	31				

FEBRUARY						
S	M	T	W	T	F	S
			1	2	3	4
5	6	7	8	9	10	11
12	13	14	15	16	17	18
19	20	21	22	23	24	25
26	27	28				

MARCH						
S	M	T	W	T	F	S
			1	2	3	4
5	6	7	8	9	10	11
12	13	14	15	16	17	18
19	20	21	22	23	24	25
26	27	28	29	30	31	

APRIL						
S	M	T	W	T	F	S
						1
2	3	4	5	6	7	8
9	10	11	12	13	14	15
16	17	18	19	20	21	22
23	24	25	26	27	28	29
30						

MAY						
S	M	T	W	T	F	S
	1	2	3	4	5	6
7	8	9	10	11	12	13
14	15	16	17	18	19	20
21	22	23	24	25	26	27
28	29	30	31			

JUNE						
S	M	T	W	T	F	S
				1	2	3
4	5	6	7	8	9	10
11	12	13	14	15	16	17
18	19	20	21	22	23	24
25	26	27	28	29	30	

JULY						
S	M	T	W	T	F	S
						1
2	3	4	5	6	7	8
9	10	11	12	13	14	15
16	17	18	19	20	21	22
23	24	25	26	27	28	29
30	31					

AUGUST						
S	M	T	W	T	F	S
		1	2	3	4	5
6	7	8	9	10	11	12
13	14	15	16	17	18	19
20	21	22	23	24	25	26
27	28	29	30	31		

SEPTEMBER						
S	M	T	W	T	F	S
					1	2
3	4	5	6	7	8	9
10	11	12	13	14	15	16
17	18	19	20	21	22	23
24	25	26	27	28	29	30

OCTOBER						
S	M	T	W	T	F	S
1	2	3	4	5	6	7
8	9	10	11	12	13	14
15	16	17	18	19	20	21
22	23	24	25	26	27	28
29	30	31				

NOVEMBER						
S	M	T	W	T	F	S
			1	2	3	4
5	6	7	8	9	10	11
12	13	14	15	16	17	18
19	20	21	22	23	24	25
26	27	28	29	30	31	

DECEMBER						
S	M	T	W	T	F	S
					1	2
3	4	5	6	7	8	9
10	11	12	13	14	15	16
17	18	19	20	21	22	23
24	25	26	27	28	29	30
31						

Meeting Date
 ## Mtg w/ Counsel
 ## LRP Workshop
 ## Conference
 ## Holiday

**STEGE SANITARY DISTRICT
BOARD OF DIRECTORS
POSITIONAL ROTATION**

DIRECTOR	TERM EXPIRES
Juliet Christian-Smith	2026
Paul Gilbert-Snyder	2024
<i>[Tessa Eve Beach]</i>	2026
Beatrice O'Keefe	2024
Dwight Merrill	2026

YEAR	POSITION	DIRECTOR
<i>2023 (proposed rotation)</i>	<i>PRESIDENT</i>	<i>Juliet Christian-Smith</i>
	<i>VICE PRESIDENT</i>	<i>Paul Gilbert-Snyder</i>
2022	PRESIDENT	Dwight Merrill
	VICE PRESIDENT	Juliet Christian-Smith
2021	PRESIDENT	Beatrice O'Keefe
	VICE PRESIDENT	Dwight Merrill
2020	PRESIDENT	Alan Miller
	VICE PRESIDENT	Beatrice O'Keefe
2019	PRESIDENT	Paul Gilbert-Snyder
	VICE PRESIDENT	Alan Miller
2018	PRESIDENT	Dwight Merrill
	VICE PRESIDENT	Jay James

ORDINANCE NO. 2213-1122 AMENDING THE STEGE SANITARY DISTRICT
ORDINANCE CODE, SECTION 4.8.2.2, LATERAL REPLACEMENT LOAN PROGRAM

ISSUE:

The Board will consider an Ordinance to amend the Stege Sanitary District Ordinance Code, Section 4.8.2.2, Lateral Replacement Loan Program.

FISCAL IMPACT:

The amendment would preserve the funds of the loan program for those that did not trigger the regional ordinance (www.eastbaypsl.com) which requires property owners to replace their private sewer laterals.

STRATEGIC PLAN:

GOAL 3: Ensure Financial Stability and Efficiency

BACKGROUND:

At the Board meeting held on September 15, 2022, the Manager reported on the status of the PSL replacement loan program. The Board asked staff to bring back an agenda item at a future board meeting to consider excluding properties that trigger the regional Private Sewer Lateral (PSL) ordinance from participating in the program.

RECOMMENDATION:

Approve the Ordinance.

ALTERNATIVES:

1. Take no action.
2. Amend the resolution and approve, as amended.

ATTACHMENTS:

- Ordinance No. 2213-1122

This Page Left Blank Intentionally

ORDINANCE NO. 2213-1122

ORDINANCE AMENDING THE STEGE SANITARY DISTRICT ORDINANCE
CODE, SECTION 4.8.2.2 - LATERAL REPLACEMENT LOAN PROGRAM

The Directors of the Stege Sanitary District find and determine as follows:

- A. The Stege Sanitary District ("District") is authorized by the Sanitary District Act of 1923 (Health & Safety Code §6400 et seq.) to provide public services and facilities related to the acquisition, construction, replacement, maintenance and operation of wastewater collection facilities within the District's service area.
- B. The District finds and determines that Infiltration and Inflow adds substantial cost to system operation and maintenance during heavy rains as additional flows are introduced to the wastewater collection system and old, leaking laterals contribute significant I&I into the wastewater collection system.
- C. The District is subject to the Consent Decree in the matter of *United State of America, et. al. v. East Bay Municipal Utility District, et. al.*, which outlines a series of activities and improvements required of the District to reduce wet weather sewage flows into the East Bay Municipal Utility District ("EBMUD") Wastewater Treatment Facilities, and to eventually eliminate the operation of, and associated discharges from, the EBMUD Wet Weather Treatment Facilities located at Point Isabel in Richmond, and San Antonio Creek and Oakport in Oakland ("Consent Decree").
- D. AB741 amended various sections of the Health and Safety Code thereby allowing public entities to enter into Contractual Assessment agreements with private property owners under which the costs of repairs to an owner's private sewer lateral can be financed and collected by use of the local county tax rolls.
- E. In order to facilitate replacement of old, leaky laterals and meet the requirements of the Consent Decree, the Board previously established a lateral replacement revolving loan program, contained in Stege Sanitary District Ordinance Code Section 4.8.

- F. Stege Sanitary District Ordinance Code Section 4.6 requires property owners to obtain a compliance certificate for the sewer lateral on their property when certain triggering events occur, such as a property sale.
- G. In order to ensure that funds remain available for the lateral replacement revolving loan program, and to facilitate the maximum number of laterals replacements and repairs as possible, the Board desires to amend the lateral replacement revolving loan program to exclude lateral repairs and replacements when a compliance certificate is otherwise required by the Code.

In consideration of the foregoing findings and determinations, it is ordained as follows:

- 1. Section 4.8.2.2 of the Stege Sanitary District Ordinance Code is hereby amended to read as set forth below:

4.8.2.2 The Lateral Replacement Loan Program may not be used for a lateral repair or replacement when a Compliance Certificate is required under Section 4.6.1 of this Code or in conjunction with any other financial assistance program(s) offered by the District.

- 2. This Ordinance is effective upon the expiration of one week from the date of publication of a summary of the Ordinance, as prescribed by California Health and Safety Code Section 6490.

* * * * *

STATE OF CALIFORNIA)
COUNTY OF CONTRA COSTA)

I HEREBY CERTIFY that the foregoing Ordinance was duly and regularly adopted by the Directors of the Stege Sanitary District, at a regular meeting thereof, held on the 10th day of November 2022 by X-X vote as follows:

AYES: BOARD MEMBERS:
 NOES: BOARD MEMBERS:
 ABSENT: BOARD MEMBERS:

ABSTAIN: BOARD MEMBERS:

DWIGHT MERRILL, President
Stege Sanitary District
Contra Costa County, California

ATTEST:

REX DELIZO, Secretary
Stege Sanitary District

ORDINANCE NO. 2214-1122 AMENDING THE STEGE SANITARY DISTRICT
ORDINANCE CODE, SECTION 4.4.5 – BACKFLOW PROTECTIVE DEVICE

ISSUE:

The Board will consider an Ordinance to amend the Stege Sanitary District Ordinance Code, Section 4.4.5 – Backflow Protective Device.

FISCAL IMPACT:

The amendment would reduce liability claims from damages resulting from sewer backups into homes.

STRATEGIC PLAN:

GOAL 3: Ensure Financial Stability and Efficiency

BACKGROUND:

At the Board meeting held on September 15, 2022, the Manager reported on the current requirements for backflow protective devices. The Board asked staff to bring back an agenda item at a future board meeting to consider requiring BPDs for all properties regardless of the elevation difference of the next upstream manhole.

RECOMMENDATION:

Approve the Ordinance.

ALTERNATIVES:

1. Take no action.
2. Amend the resolution and approve, as amended.

ATTACHMENTS:

- Ordinance No. 2214-1122

This Page Left Blank Intentionally

ORDINANCE NO. 2214-1122

ORDINANCE AMENDING THE STEGE SANITARY DISTRICT ORDINANCE
CODE, SECTION 4.4.5 – BACKFLOW PROTECTIVE DEVICE

The Directors of the Stege Sanitary District find and determine as follows:

- A. The Stege Sanitary District Ordinance Code establishes requirements for certain buildings to have Backflow Protective Devices.
- B. Backflow Protective Devices are a critical tool for protecting health and safety by preventing sewer backups into occupied buildings.
- C. The Board desires to amend Stege Sanitary District Ordinance Code Section 4.4.5 regarding Backflow Protective Devices in order to strengthen and clarify the District's requirements for Backflow Protective Devices.

In consideration of the foregoing findings and determinations, it is ordained as follows:

- 1. Section 4.4.5 of the Stege Sanitary District Ordinance Code is hereby amended as set forth below:

4.4.5 Backflow ~~Prevention Protective~~ Device. All new and existing building Laterals₂ including Lateral replacements₂ shall be equipped with a cleanout riser. ~~All new building Laterals shall and~~ be ~~also~~ fitted with a backflow prevention device of type and materials as approved by the District. ~~In addition, existing Buildings in which the elevation of the lowest floor is less than twelve (12) inches above the rim elevation of the nearest upstream manhole or junction structure in the reach of a District Main Sewer into which a Building Sewer, through a Lateral, connects shall be protected from backflow of Sewage by installing a backflow protective device of a type and in the manner prescribed by the District.~~ Any such backflow prevention ~~protective~~ device shall be installed by the owner of the property on which the building is constructed, and shall be located on the Building Sewer between the building and the property line, preferably at the location of the cleanout. The backflow prevention ~~protective~~ device, if below grade, shall be enclosed

in a suitable concrete utility box with removable cover and shall be readily accessible for inspection and maintenance. The installation of any such backflow ~~prevention protective~~-device shall be at the sole cost and expense of the property owner. The maintenance of the backflow ~~prevention protective~~ device shall be the sole obligation of the owner or the owner's successor in interest. The District shall be under no obligation to ascertain that the backflow ~~prevention protective~~-device continues in operating condition.

- 2. This Ordinance is effective upon the expiration of one week from the date of publication of a summary of the Ordinance, as prescribed by California Health and Safety Code Section 6490.

* * * * *

STATE OF CALIFORNIA)
COUNTY OF CONTRA COSTA)

I HEREBY CERTIFY that the foregoing Ordinance was duly and regularly adopted by the Directors of the Stege Sanitary District, at a regular meeting thereof, held on the 10th day of November 2022 by X-X vote as follows:

AYES: BOARD MEMBERS:
NOES: BOARD MEMBERS:
ABSENT: BOARD MEMBERS:
ABSTAIN: BOARD MEMBERS:

DWIGHT MERRILL, President
Stege Sanitary District
Contra Costa County, California

ATTEST:

REX DELIZO, Secretary
Stege Sanitary District

RESOLUTION NO. 2215-1122 FINDING THAT THERE IS A PROCLAIMED STATE OF EMERGENCY; FINDING THAT MEETING IN PERSON WOULD PRESENT IMMINENT RISKS TO THE HEALTH OR SAFETY OF ATTENDEES AS A RESULT OF THE STATE OF EMERGENCY; AND AUTHORIZING REMOTE TELECONFERENCED MEETINGS OF THE STEGE SANITARY DISTRICT FOR THE 30 DAY PERIOD BEGINNING NOVEMBER 10 PURSUANT TO AB 361

ISSUE:

The Board will consider a resolution making necessary findings to continue to meet remotely for another 30-day period pursuant to Assembly Bill 361 (AB 361).

FISCAL IMPACT:

The fiscal impact to continue to meet remotely is minimal.

STRATEGIC PLAN:

GOAL 4: Provide a Safe and Rewarding Work Environment that Recognizes the Worth and Value of Employees

BACKGROUND:

On September 16, 2021, Governor Gavin Newsom signed AB 361 which allows public agencies to continue to meet remotely when there is a declared State of Emergency and pursuant to certain procedural requirements. AB 361 essentially allows the District to continue to meet remotely under similar circumstances as under the Governor's Executive Order N-29-20, allowing local agencies to meet remotely. The teleconferencing provisions of Executive Order N-29-20 expired on September 30.

AB 361 allows the following:

- While maintaining transparency and public access, local agencies would be able to meet remotely during a declared state of emergency
- While agencies would still be required to post agendas and meeting information, agencies would not be required to post meeting notices and/or agendas at all teleconference locations when remotely meeting during an emergency
- While the public must continue to have access to the remote meeting and provided the ability to make public comment, agencies would not be required to make all remote meeting sites accessible to the public, nor include the remote location details in the meeting notice or agenda during a declared state of emergency
- Additionally, agency board members would not be required to be at remote sites within the territorial bounds of the agency during a declared state of emergency

Since September 23, 2021, pursuant to AB 361, the Board has approved recurring resolutions authorizing remote teleconferenced meetings for a 30-day period.

Pursuant to AB 361, a draft resolution to extend remote teleconferenced meetings for another 30-day period is attached for the Board's consideration.

RECOMMENDATION:

Approve the resolution.

ALTERNATIVES:

1. Take no action.
2. Amend the resolution and approve, as amended.

ATTACHMENTS:

- Resolution No. 2215-1122

RESOLUTION NO. 2215-1122

RESOLUTION FINDING THAT THERE IS A PROCLAIMED STATE OF EMERGENCY; FINDING THAT MEETING IN PERSON WOULD PRESENT IMMINENT RISKS TO THE HEALTH OR SAFETY OF ATTENDEES AS A RESULT OF THE STATE OF EMERGENCY; AND AUTHORIZING REMOTE TELECONFERENCED MEETINGS OF THE STEGE SANITARY DISTRICT FOR THE 30 DAY PERIOD BEGINNING NOVEMBER 10 PURSUANT TO AB 361

The Directors of the Stege Sanitary District (District) find and determine as follows:

- A. All meetings of the District are open and public, as required by the Ralph M. Brown Act (Cal. Gov. Code 54950 – 54963), so that any member of the public may attend, participate, and watch the District conduct its business; and.
- B. On March 4, 2020, Governor Newsom declared a State of Emergency to make additional resources available, formalize emergency actions already underway across multiple state agencies and departments, and help the State prepare for a broader spread of the novel coronavirus disease 2019 (COVID-19).
- C. On March 17, 2020, in response to the COVID-19 pandemic, Governor Newsom issued Executive Order N-29-20 suspending certain provisions of the Ralph M. Brown Act in order to allow local legislative bodies to conduct meetings telephonically or by other means.
- D. As a result of Executive Order N-29-20, staff set up virtual meetings for all Board meetings.
- E. On June 11, 2021, Governor Newsom issued Executive Order N-08-21, which, effective September 30, 2021, ends the provisions of Executive Order N-29-20 that allows local legislative bodies to conduct meetings telephonically or by other means.
- F. On September 16, 2021, the Governor signed AB 361 (2021) which allows for local legislative bodies and advisory bodies to continue to conduct meetings via teleconferencing under specified conditions and includes a requirement that the Board make specified findings. AB 361 (2021) took effect immediately.

- G. AB 361 (2021) requires that the Governor declare a State of Emergency pursuant to Government Code section 8625.
- H. AB 361 (2021) further requires that state or local officials have imposed or recommended measures to promote social distancing, or, requires that the legislative body determines that meeting in person would present imminent risks to the health and safety of attendees.
- I. Such conditions now exist in the District, specifically, Governor Newsom has declared a State of Emergency due to COVID-19.
- J. Since issuing Executive Order N-08-21, the highly contagious Delta and Omicron variants of COVID-19 have emerged, causing an increase in COVID-19 cases throughout the State and Contra Costa County.
- K. On August 2, 2021, in response to the Delta variant of COVID-19, the Contra Costa County Health Officer issued an order for nearly all individuals to wear masks when inside public spaces and on September 14, 2021, issued an order requiring operators of specified dining establishments, entertainment venues and fitness facilities to restrict entry based on COVID-19 vaccination status or testing.
- L. The Centers for Disease Control and Prevention (“CDC”) continues to recommend physical distancing of at least 6 feet from others outside of the household and the Contra Costa County Health Officer strongly recommends online meetings and distancing.
- M. The highly contagious Omicron variant and sub-variants have resulted in the greatest nationwide infection rate since the beginning of the COVID-19 pandemic; and
- N. Because of the rise in cases due to the Omicron variant and sub-variant of COVID-19, the District is concerned about the health and safety of all individuals who intend to attend Board meetings.
- O. On September 23, 2021, the Board found that the presence of COVID-19 and the increase of cases due to the Delta variant would present imminent risks to the health or safety of attendees, including the Board and staff, should the Board hold in person meetings; and

- P. The Board hereby finds that the presence of COVID-19 and the increase of cases due to the Omicron variant and sub-variants would present imminent risks to the health or safety of attendees, including the Board and staff, should the Board hold in person meetings.
- Q. The District shall ensure that its meetings comply with the provisions required by AB 361 (2021) for holding teleconferenced meetings.

In consideration of the foregoing findings and determinations, it is resolved:

1. The foregoing recitals are true and correct and are hereby incorporated by reference
2. In compliance with AB 361 (2021), and in order to continue to conduct teleconference meetings without complying with the usual teleconference meeting requirements of the Brown Act, the Board makes the following continued findings:
 - a) The Board has considered the circumstances of the state of emergency; and
 - b) The state of emergency, as declared by the Governor, continues to directly impact the ability of the Board, as well as staff and members of the public, from meeting safely in person; and
 - c) The CDC continues to recommend physical distancing of at least six feet due to COVID-19 and the Contra Costa County Health Officer strongly recommends online meetings and distancing. As a result of the presence of COVID-19 and the increase of cases due to the Omicron variant and sub-variants, meeting in person would present imminent risks to the health or safety of attendees, the Board, and staff.
3. The Board may continue to meet remotely in compliance with AB 361, in order to better ensure the health and safety of the public.
4. The Board will revisit the need to conduct meetings remotely within 30 days of the adoption of this resolution.

* * * * *

STATE OF CALIFORNIA)
COUNTY OF CONTRA COSTA)

I HEREBY CERTIFY that the foregoing Resolution was duly and regularly adopted by the Directors of the Stege Sanitary District, at a regular meeting thereof, held on the 10th day of November 2022 by a X-X vote as follows:

AYES: BOARD MEMBERS:
NOES: BOARD MEMBERS:
ABSENT: BOARD MEMBERS:
ABSTAIN: BOARD MEMBERS:

DWIGHT MERRILL, President
Stege Sanitary District
Contra Costa County, California

ATTEST:

REX DELIZO, Secretary
Stege Sanitary District

RESOLUTION NO. 2216-1122 APPROVING A CONTRACT WITH WECO INDUSTRIES,
LLC FOR A 2023 GAPVAX MC1007-3S3X COMBINATION JET/VAC IN THE AMOUNT
NOT TO EXCEED \$559,281.43

ISSUE:

The District Manager requires authorization from the Board of Directors to procure a new replacement combination water jetting and vacuum system sewer cleaning truck.

FISCAL IMPACT:

The cost of a new 2023 GapVax MC1007-3S3X Combination Water Jetting and Vacuum System Sewer Cleaning Truck is \$559,281.43 and is scheduled for the 2024-25 fiscal year budget.

STRATEGIC PLAN:

GOAL 2: Maintain and Improve Infrastructure

WORK PLAN ITEM "a": Perform proactive maintenance and assessment of the sewer system through cleaning, CCTV inspection and chemical root control to eliminate "preventable" SSOs

BACKGROUND:

The existing 2012 *Vac-Con* combination water jetting and vacuum system sewer cleaning truck (combo unit) is frequently in need of repairs and is nearing the end of its useful life. The District's newer existing combo unit is a 2018 *GapVax* combo unit and staff would prefer to keep the fleet consistent to facilitate training, repairs, maintenance, and replacement parts.

The proposed new GapVax combo unit has a lead time of up to 2 years and has been increasing in price due to lack of supply and increased demand. It would be in the best interest of the District to lock in the current price now with a delivery date around July 2024.

WECO Industries, LLC is the sole authorized supplier of all GapVax, Inc. products in the territory of Northern California, Porterville and every area north of it, as provided in a communication from GapVax, Inc. to the District (attached). The GapVax combo unit is a unique or innovate concept and the only product that can provide for the District's needs.

RECOMMENDATION: Approve the Resolution.

ATTACHMENTS:

- Resolution No. 2216-1122
- GapVax Quote
- GapVax Sole Source Letter

This Page Left Blank Intentionally

RESOLUTION NO. 2216-1122

RESOLUTION APPROVING A CONTRACT WITH WECO INDUSTRIES, LLC FOR A 2023 GAPVAX MC1007-3S3X COMBINATION WATER JETTING AND VACUUM SYSTEM SEWER CLEANING TRUCK IN THE AMOUNT NOT TO EXCEED \$559,281.43

The Directors of the Stege Sanitary District find and determine as follows:

- A. The District has the need for a new 2023 GapVax MC1007-3S3X Combination Water Jetting and Vacuum System Sewer Cleaning Truck (“GapVax Combo Unit”).
- B. WECO Industries, LLC is the sole authorized supplier of all GapVax, Inc. products in the territory of Northern California, Porterville and every area north of it, as provided in the communication from GapVax, Inc. to the District.
- C. The GapVax Combo Unit is a unique or innovate concept and the only product that can provide for the District’s needs.
- D. The Directors of the Stege Sanitary District desire to approve and authorize the District Manager to execute an agreement with WECO Industries, LLC to purchase the GapVax Combo Unit.

In consideration of these findings and determinations, it is resolved as follows:

- 1. The District Manager is authorized to execute a contract, in a form approved by District Counsel, with WECO Industries, LLC in an amount not to exceed \$559,281.43 for a new 2023 GapVax MC1007-3S3X Combination Water Jetting and Vacuum System Sewer Cleaning Truck.

* * * * *

STATE OF CALIFORNIA)
COUNTY OF CONTRA COSTA)

I HEREBY CERTIFY that the foregoing Resolution was duly and regularly adopted by the Directors of the Stege Sanitary District, at a regular meeting held on the 10th day of November 2022, by a X-X vote as follows:

AYES: BOARD MEMBERS
NOES: BOARD MEMBERS:
ABSENT: BOARD MEMBERS:
ABSTAIN: BOARD MEMBERS:

DWIGHT MERRILL, President
Stege Sanitary District
Contra Costa County, California

ATTEST:

REX DELIZO, Secretary
Stege Sanitary District



October 14, 2022

Stege Sanitary District
Rex Delizo
District Manager

Mr. Delizo,

WECO has Quoted Stege SD another GAPVAX Combination Machine with current pricing. If the district places the order by 11-30-22, WECO will honor the pricing.

WECO will not deliver or invoice the District until after July 1st, 2024 regardless of when it arrives to WECO. The unit will be stored in our warehouse until delivery if needed.

The District can have the comment written on the PO "Not to be delivered until after July 1, 2024".

I have attached the Quote with an expiration date of 11-30-22.

Thank you.

A handwritten signature in black ink that reads "Tom Johnson". The signature is written in a cursive style.

Tom Johnson
Owner
WECO Industries, LLC

PLEASE DOWNLOAD NEWEST VERSION

GapVax[®]



PREPARED BY

WECO Industries

LEIGHTON WHITE - leightonwhite@wecoind.com

PREPARED FOR

DENNIS WRIGHT
STEGE SANITARY DISTRICT
7500 SCHMIDT LANE
EL CERRITO, CA 94530

QUOTE

GapVax



QUOTE ID
101422

UPDATED:
6/13/2022

PROPOSAL NO.
101422

DISTRIBUTOR
WECO Industries

MODEL
MC1007

CHASSIS
PETERBILT 548 (4 X 2) - 360 HP - 50,000 LB. G

CHASSIS YEAR
2023

SOURCEWELL PRICING
NO

CONTACT
DENNIS WRIGHT

END USER
STEGE SANITARY DISTRICT

ADDRESS
7500 SCHMIDT LANE

CITY, STATE, ZIP
EL CERRITO, CA 94530

PHONE NUMBER
510-524-4468

EMAIL
dennis@stegesan.org

SALES REPRESENTATIVE
LEIGHTON WHITE

SALES REP. EMAIL
leightonwhite@wecoind.com

HGAC COMPATIBLE		
Chassis		TRUE
Model		TRUE

LIST	DEALER	PRICING LEVEL
2	2	2022



2023 MC1007-3S3X COMBINATION JET/VAC

QUOTE ID: 101422

October 14, 2022

NOTE: THE GAPVAX MC UNIT MAY EXCEED FEDERAL BRIDGE ALLOWABLE WEIGHTS WHEN LOADED WITH WATER, OR DEBRIS, AND/OR BOTH WATER AND DEBRIS COMBINED. PLEASE CONSULT FACTORY.

	OPTION DESCRIPTION	NOTES	QTY	PRICE			
CHASSIS OPTIONS							
CHA001	PETERBILT 548 (4 X 2) - 360 HP - 50,000 LB. GVWR - AUTO	MODEL YEAR 2023	1	\$165,000			
	PACCAR PX-9 RATED FOR 360 HP	CONSULT FACTORY		\$0			
	ALLISON 6 SPEED AUTOMATIC	PRICES MAY VARY		\$0			
	20,000 LB FRONT AXLE			\$0			
	30,000 LB REAR AXLE			\$0			
	WHITE CAB COLOR		1	\$0			
	CURRENT EPA EMISSIONS (48 STATES, EXCLUDES CALIFORNIA AND NEW JERSEY)		1	\$0			
	CURRENT CARB EMISSIONS, CALIFORNIA AND NEW JERSEY		1	\$2,500			
	STOCK CHASSIS ARE SUBJECT TO PRIOR SALE, LIMITED QUANTITY ARE AVAILABLE		1	\$0			
DEBRIS BODY OPTIONS							
STD	7 USABLE YARD DEBRIS TANK MADE OF 3/16" ASTM A-572 GRADE 50 EXTEN STEEL		STANDARD	STANDARD			
STD	FULL-OPENING REAR TAILGATE		STANDARD	STANDARD			
STD	STAINLESS STEEL TAILGATE SEALING ROD		STANDARD	STANDARD			
STD	FOUR HYDRAULIC REAR DOOR LOCKS		STANDARD	STANDARD			
STD	DUAL TAILGATE LIFT CYLINDERS		STANDARD	STANDARD			
STD	FRONT MOUNTED HOIST CYLINDER, POWER UP AND DOWN, 55,000 LB CAPACITY		STANDARD	STANDARD			
STD	THREE TIE-OFF ANCHORS ON TOP OF BODY		STANDARD	STANDARD			
STD	FIVE YEAR WARRANTY ON DEBRIS TANK AGAINST RUST THROUGH, DISTORTION AND CRACKS		STANDARD	STANDARD			
STD	THREE TIE-OFF ANCHORS ON TOP OF THE BODY 6' APART		STANDARD	STANDARD			
A1B	STAINLESS DEBRIS BODY FLUSH OUT SYSTEM		1	\$2,860			
A2A	DRAIN AT BOTTOM OF TAILGATE - 6" BRASS LEVER VALVE WITH 15' OF LAYFLAT HOSE	VALVE IS NOT 100% LEAK PROOF	1	\$880			
A3-CS	FLOAT TYPE LIQUID LEVEL INDICATOR ON SIDE OF DEBRIS TANK		1	\$1,120			
A11A	FILTER SCREEN FOR DRAIN VALVE (SHORT BOX)	REQUIRES A2	1	\$690			
A21	CURBSIDE LADDER TO PORT INSPECTION AREA		1	\$2,100			
A21B	ADD FOLDING LADDER EXTENSION	REQUIRES A21	1	\$1,035			
A18	PURGE VALVE AT GRAVITY DRAIN (1-1/4" BALL VALVE)		1	\$405			
A44	PNEUMATIC TAILGATE PROP (IN ADDITION TO STANDARD TAILGATE PROP ROD)		1	\$990			
WATER TANK OPTIONS							
STD	1000 GALLON WATER TANK MADE OF 3/16" 304 STAINLESS STEEL		STANDARD	0			
STD	4" HIGH ANTI-SIPHON RING WITH (4) 2-1/2" HOLES		STANDARD	0			
STD	WATER TANK LEVEL SIGHT TUBE ON CURBSIDE		STANDARD	0			
STD	DRAIN VALVE AT BOTTOM OF WATER TANK		STANDARD	0			
STD	3" FILL LINE WITH 2-1/2" FIRE HOSE CONNECTION CURBSIDE		STANDARD	0			
STD	3" WATER STRAINER WITH STAINLESS STEEL SCREEN ON WATER TANK FILL LINE		STANDARD	0			
STD	3" SUPPLY LINE TO WATER PUMP MOUNTED AT REAR HINGE PIN		STANDARD	0			
STD	FIVE YEAR WARRANTY ON WATER TANK AGAINST RUST THROUGH, DISTORTION AND CRACKS		STANDARD	0			
B10	ADDITIONAL 3" FILTER BETWEEN WATER TANK AND PUMP (3" Y-STRAINER)		1	\$1,290			
B23B	STAINLESS BAFFLES IN THE WATER TANK		1	\$1,820			
B30	UPGRADE TO BUTTERFLY VALVE IN 3" SUPPLY LINE		STANDARD	\$0			
VACUUM SYSTEM OPTIONS							
STD	TRUE 8" DIAMETER VACUUM SYSTEM		STANDARD	0			
STD	VACUUM PUMP DRIVEN VIA MID-SHIP MOUNTED SPLIT SHAFT TRANSFER CASE GEARBOX (PTO)		STANDARD	0			
STD	NOISE & VIBRATION DAMPENING MOUNTS ON VACUUM PUMP AND TRANSFER CASE		STANDARD	0			
STD	NOISE ATTENUATED VACUUM PUMP DISCHARGE SILENCER WITH RAIN CAP AND DRAIN		STANDARD	0			
STD	24" CENTRIFUGAL CYCLONE SEPARATOR WITH 20" CHAMBER		STANDARD	0			
STD	DUAL STAINLESS STEEL SHUTOFF FLOAT BALLS MOUNTED AT THE REAR OF DEBRIS TANK		STANDARD	0			
STD	STAINLESS STEEL VEE-WIRE SAFETY SCREEN		STANDARD	0			
STD	6" SAFETY VACUUM RELIEF		STANDARD	0			
STD	PANIC SWITCH FUNCTION FOR VACUUM		STANDARD	0			
C8	UPGRADE TO ROOTS TYPE VACUUM PUMP 4,500 CFM AND 18" HG	(4) 18" Hg VACUUM RELIEF VALVES	1	\$12,935			
WATER SYSTEM OPTIONS							
STD	TRI-PLEX WATER PUMP SYSTEM		STANDARD	STANDARD			
STD	800 PSI WASHDOWN CIRCUIT WITH 50' X 1/2" HOSE		STANDARD	STANDARD			

STD	AIR PURGE SYSTEM FOR PRIMARY CIRCUIT	STANDARD	STANDARD			
STD	LOW POINT DRAIN VALVES ON WATER LINES	STANDARD	STANDARD			
STD	SET WASHDOWN CIRCUIT TO 800 PSI	1	\$0			
D5A	GIANT GP8000 SERIES WATER PUMP RATED AT 63 GPM @ 3000 PSI	1	\$4,265			
D4A	UPGRADE TO URACA MULTIFLOW VALVE - SET WASHDOWN CIRCUIT TO 800 PSI	1	\$2,475			
D7A	50' X 1/2" HAND GUN REEL FOR WASHDOWN CIRCUIT	1	\$1,295			
D8	EXTRA HANDGUN CONNECTION WITH 50' X 1/2" HOSE	1	\$895	HOSE REEL NOT INCLUDED		
D7B	50' X 1/2" HAND GUN REEL FOR HX CIRCUIT	1	\$1,295			
D35B	1/2" HX LANCE WITH 6' EXTENSION AND RIPS AW NOZZLE	1	\$970			
BOOM OPTIONS						
STD	8' FRONT MOUNTED TELESCOPING BOOM WITH 26' REACH AND 180 DEG. ROTATION	STANDARD	0			
STD	180 DEGREE POWER ROTATION VIA WORM DRIVE	STANDARD	0			
STD	DUAL 4" LIFT CYLINDERS	STANDARD	0			
STD	CAB PROTECTION RACK	STANDARD	0			
E6	REMOTE LUBE FOR BOOM LIFT AND ROTATION	1	\$3,165			
E7	3/16" HEAVY DUTY BOOM ELBOW WITH 6" FORMED CHANNEL RADIUS	1	\$1,210			
HOSE REEL OPTIONS						
STD	FRONT FRAME MOUNTED HOSE REEL WITH 180 DEGREE ARTICULATION	STANDARD	0			
STD	HOSE REEL RATED FOR 800' OF HOSE AND 3,000 PSI	STANDARD	0			
STD	EXTERIOR HOSE EXPANSION RIBS	STANDARD	0			
F1C	DIGITAL FOOTAGE COUNTER - SHAFT-MOUNTED	1	\$2,675			
F6	UPGRADE FRONT HOSE REEL TO POWER ARTICULATE VIA HYDRAULICS	1	\$5,825			
F16	DOUBLE ROLLER UPGRADE ON MANUAL LEVEL WIND	1	\$780			
CONTROLS, GAUGES, ACCESSORIES OPTIONS						
STD	CAB-MOUNTED AIR SHIFT CONTROLS FOR BLOWER, HYDRAULICS, AND WATER PUMP	STANDARD	0			
STD	CONTROL PANEL MOUNTED AT FRONT HOSE REEL	STANDARD	0			
STD	OPERATOR CONTROL PANEL INCLUDES GAUGES FOR ENGINE, HYDRAULICS, VACUUM, AND WATER PUMP	STANDARD	0			
STD	PANIC SWITCH TO RELIEVE WATER PRESSURE AND VACUUM	STANDARD	0			
STD	30' PENDANT REMOTE WITH BOOM FUNCTIONS	STANDARD	0			
G2B	G2B CONTROL SYSTEM WITH DM430 DISPLAY INCLUDES:	1	\$3,060			
	LOW WATER SHUTDOWN PROTECTION	1	\$0			
	HIGH WATER TEMPERATURE SHUTDOWN PROTECTION	1	\$0			
	ENGINE OVERSPEED PROTECTION	1	\$0			
	ON-SCREEN DIAGNOSTICS FOR WATER, PTO AND ENGINE LEVELS	1	\$0			
G4A	HIGH DEBRIS LEVEL LIGHT & ALARM WIRED TO VACUUM RELIEF	1	\$1,325	REQUIRES A3		
	WIRELESS REMOTE	STANDARD	0			
G19	WIRELESS REMOTE WITH BOOM AND VACUUM FUNCTIONS	1	\$3,920			
G30	ADDITIONAL ELECTRICAL SWITCH ON CONTROL PANEL	1	\$360			
LIGHTING						
STD	TRUCK-LITE LED RUNNING (MARKER) LIGHTS	STANDARD	0			
STD	LED STOP/TAIL/TURN LIGHT WITH POLISHED STAINLESS STEEL BOXES	STANDARD	0			
H1C	ONE LED STROBE BEACON LIGHT - FRONT (CALIFORNIA TITLE-13 COMPLIANT)	1	\$655	(CODE 3 MN: LSS222A OR EQUAL) (P/N: LHT022539)		
H5B	(2) BOOM WORK LIGHTS - HELLA LED WORK LIGHTS (PN: LHT022429)	1	\$975			
H6B	(2) REAR WORK LIGHTS - HELLA LED WORK LIGHTS (PN: LHT022429)	1	\$800			
H7BC	(4) SIDE WORK LIGHTS - HELLA LED WORK LIGHTS (PN: LHT022429) (2 PER SIDE)	1	\$1,190			
H33	REAR ARROW LIGHT - LOW PROFILE LED (CA TITLE-13 COMPLIANT) TRAFFIC ADVISOR	1	\$2,165	(LHT022544, CODE 3 TORUS NARROWSTIK OR EQUAL)		
H39B	TWO HIGH INTENSITY LED WORK LIGHTS (HELLA PB1500) ON FRONT HOSE REEL TO SHINE INTO MANHOLE	1	\$1,145			
STORAGE OPTIONS						
STD	25' FIRE HOSE BASKET	STANDARD	0			
STD	TWO (2) GALVANIZED STEEL TUBE TRAYS	STANDARD	0			
I6D-DS	STAINLESS STEEL, 30" WIDE X 24" TALL X 24" DEEP, MOUNTED ON THE DRIVER'S SIDE	1	\$840			
I9C	48" TOOL BOX - STAINLESS STEEL, 48" WIDE X 24" HIGH X 24" DEEP, MOUNTED ON THE CURBSIDE	1	\$2,475			
I14	TRAFFIC CONE HOLDER ON DRIVER'S SIDE	1	\$210			
I14C	TRAFFIC CONE HOLDER ON CURBSIDE	1	\$210			
I16A	WHEEL CHOCK HOLDER (PER SIDE) - DRIVER'S SIDE	1	\$280			
I16B	WHEEL CHOCK HOLDER (PER SIDE) - CURBSIDE	1	\$280			
I17B	NOZZLE RACK - SIX (6) NOZZLES, 3/4"	1	\$210			
I20A	REAR DRAIN HOSE RACK FOR 6" LAYFLAT HOSE X 15' LONG	1	\$210			
CHASSIS OPTIONS						
STD	DOT LIGHTING / FENDERS / MUD FLAPS / TAILGATE SAFETY PROP, ICC LIGHTS	STANDARD	0			
STD	REMOTE ACTUATED BODY SAFETY PROP	STANDARD	0			
STD	70 GALLONS AW-46 HYDRAULIC OIL, LEVEL/TEMPERATURE GAUGE, SHUTOFF ON SUCTION	STANDARD	0			
STD	REAR BUMPER, TRIANGLE KIT, FIRE EXTINGUISHER, BACKUP ALARM	STANDARD	0			

STD	ALLISON 10-BOLT PTO UPGRADE	STANDARD	0			
J0	FRONT BUMPER - MAY NOT BE REQUIRED IN ALL STATES	1	\$655			
J3	TOW HOOKS FRONT	1	\$405			
J4B	TOW HOOKS REAR - FRAME MOUNTED	1	\$405			
J18	REMOTE LUBE OF TAILGATE LIFT COMPONENTS AND TAILGATE LOCKS	1	\$3,365			
J21	LICENSE PLATE HOLDER ON BACK OF TUBE TRAY	REQUIRED FOR CALIFORNIA	1	\$340		
J22	STAINLESS STEEL DUMP APRON / PAN ON REAR BUMPER	NOT COMPATIBLE WITH J16	1	\$855		
PAINT OPTIONS						
STD	PAINTED WITH PPG URETHANE PAINT	STANDARD	0			
STD	PAINT BODY WHITE	STANDARD	0			
STD	PAINT FRAME AND PARTS BLACK	STANDARD	0			
STD	PAINT HOSE REEL AND BOOM BLACK	STANDARD	0			
STD	FLEET FINISH	STANDARD	0			
MISCELLANEOUS OPTIONS						
STD	25 FEET OF VACUUM TUBING (5) AND CLAMPS	STANDARD	0			
STD	TIGER TAIL HOSE GUIDE	STANDARD	0			
STD	TWO BLUE STAR SEWER CLEANING NOZZLES	STANDARD	0			
M3	FILL HOSE 25' X 2 1/2"	1	\$255			
M5B	LEADER HOSE 10' X 3/4"	1	\$170			
M9F	3/4" COBRA SEWER HOSE - 3,000 PSI X 800 FT PLASTIC (BLUE) (PN: HOS022495)	1	\$2,700			
M27	TIGER TAIL (TOTAL OF TWO)	1	\$60			
M29B	TWO CAMERA - BACK-UP CAMERA SYSTEM WITH 7" COLOR MONITOR (RV-505A), INCLUDES DVR-916 REAR AND DVR-921 FRONT CAMERA	1	\$2,975			
CUSTOM OPTIONS						
**	MATERIALS SURCHARGE (EFFECTIVE MAY 1, 2022)	1	\$10,000			
*****	PLUMBING FROM PUMP TO HOSE REEL MUST BE 1"	1	\$0			
*****	ONE WASH DOWN SET TO 800PSI, ONE WASHDOWN SET TO FULL WORKING PRESSURE	1	\$0			
*****	CA STATE SALES TAX @ 10.25%, NO TAX ON FREIGHT	1	\$0			
*****	*****DUE TO PRICING INSTABILITY, QUOTE EXPIRES 11-30-22	1	\$0			



PRICING SUMMARY

PRICE OF BASE UNIT WITH OPTIONS:	\$ 499,575.00
DELIVERY: (\$1,000.00 MINIMUM) @ \$3.00 PER MILE	\$ 8,500.00
ESTIMATED SUBTOTAL:	\$ 508,075.00
SALES TAX:	\$ 51,206.43
TOTAL PRICE (PER UNIT):	\$ 559,281.43

DUE TO EXTREME MARKET VOLATILITY AND PENDING U.S. GOVERNMENT SECTION 232 TRADE CASES ALL PRICES AND AVAILABILITY ARE SUBJECT TO CHANGE WITHOUT NOTICE, ALL QUOTES TO BE CONFIRMED AT TIME OF ORDER

*** FOB DESTINATION ***

PRINT TERMS	NO	
TAX EXEMPT	YES	Removes FET
INTERNATIONAL	NO	Changes Terms
TRADE-IN	NO	Replaces Discount
VIEW	B	
TEXAS BUY BOARD	NO	BLANK
		TOTAL PRICE, LES

	SOURCEWELL DIS

SIGNATURE _____

DATE _____

Please return a signed copy to leightonwhite@wecoind.com

QUOTE ID
101422

LAST UPDATED:
6/13/2022

GapVax Incorporated

Terms and Conditions of Sale

1. **ORDERS.** All orders are subject to acceptance by an officer of GapVax Inc. Orders for products not regularly carried in stock or requiring special engineering or manufacture are in every case subject to approval by an officer of GapVax.
2. **PERFORMANCE.** GapVax Inc. shall not be liable for failure to complete the contract in accordance with its terms if failure is due to wars, strikes, fires, floods, accidents, delays in transportation or other causes beyond its reasonable control.
3. **EXPERIMENTAL WORK.** Work performed at customer's request such as sketches, drawings, design, testing, fabrication and materials shall be charged at current rates.
4. **SKETCHES, ENGINEERING DRAWINGS, MODELS** and all preparatory work created or furnished by GapVax Inc. shall remain its exclusive property; and no use of same shall be made, nor may ideas obtained therefrom be used, except with the consent of and on terms acceptable to GapVax Inc.
5. **CANCELLATION.** Orders regularly entered cannot be canceled except upon terms that will compensate GapVax Inc. for any loss or damage sustained.
6. **SHIPMENT.** All proposals are based on continuous and uninterrupted delivery of the order upon completion unless specifications distinctly state otherwise. In the event that an agreement is reached for GapVax Inc. to store completed items, they will be immediately invoiced to the customer and become due and payable. Storage shall be at the risk of the customer and GapVax Inc. shall be liable only for ordinary care of the property.
7. **CUSTOMER'S PROPERTY.** GapVax Inc. shall charge the customer at current rates, for handling and storing customer's property (e.g., truck chassis) held for more than thirty (30) days after notification of availability for shipment. All customer's property, or third party's property, that is stored by GapVax Inc. is at the customer's or other party's risk. GapVax Inc. is not liable for any loss or damage thereto caused by fire, water, corrosion, theft, negligence, or any cause beyond its reasonable control.
8. **PRICES.** All orders are subject to current prices in effect at the time of order acknowledgment. Prices and Specifications are Subject to Change Without Notice. **PRICING DISCLAIMER:** While we make every effort to maintain and preserve pricing accuracy, prices are subject to change without notice. Although the information on this quotation is presented in good faith and believed to be correct at the time of printing, we make no representations or warranties as to the completeness or accuracy of this information. We reserve the right to change, delete, or otherwise modify the pricing information which is represented herein without any prior notice. We carefully check pricing specifications, but occasionally errors can occur, therefore we reserve the right to change such prices without notice. We disclaim all liability for any errors or omissions in the materials. In no event will we be responsible for any damages of any nature whatsoever from the reliance upon information from these materials. Please check your order to confirm your pricing information.
9. **F.O.B. POINT.** Unless otherwise stated, all prices listed are F.O.B. point of manufacture.
10. **TAXES.** Unless specifically stated, prices listed do not include Federal, State, City or other excise occupation, sales, use or similar taxes which are extra and are to be added at rates in effect at time of shipment. If Federal Excise Taxes are included or listed on the reverse side of this paper, they are stated at the rates and regulations in effect at the time this order is written and are subject to revision in accordance with rates and regulations in effect at time of shipment.
11. **PRODUCT IMPROVEMENT.** GapVax Inc. reserves the right to change manufacturing specifications and procedures without incurring any responsibility for modifying previously shipped products.
12. **MOUNTING PRICES.** Mounting prices assumes normal factory installation on a truck chassis suitable for the unit purchased. Relocation of batteries, gas tanks, mufflers, air tanks, etc. will be an additional charge, billed at the standard factory labor rate.
13. **WARRANTY.** GapVax Inc. warrants its products to be free from defects in material and workmanship, subject to the limitations and conditions set forth in its current published warranty but makes no warranty of merchantability or fitness for any particular purpose. GapVax Inc. does not assume liability for any loss of product, time or any direct, indirect, or consequential damage, losses or delay or any nature whatsoever. No warranty, express or implied, is made or authorized to be made and no obligation is assumed or authorized to be assumed with respect to products of GapVax Inc. other than that set forth in the current, published warranty. It is to be understood that the acceptance of this order is expressly conditioned upon your acceptance of GapVax Inc. standard written warranty for the products sold hereunder. GapVax Inc. hereby disclaims any responsibility or liability for any consequential losses, delays or downtime resulting from orders hereunder the use of its products. GapVax does not and will not warrant any tank coating or tank lining. PTO damage is not covered when the PTO protection system or low water shut down system is not selected / installed / and operational. GapVax does not and will not warrant any water system component(s) that show any sign or indication of ice or freeze damage.
14. This agreement shall be construed according to the laws of the State of Pennsylvania. Our failure at any time to exercise any right we may have under the agreement shall not constitute a waiver thereof nor prejudice our right to enforce same thereafter.
15. This order, including the above terms and conditions contains the complete and final agreement between the parties hereto and no other agreement in any way modifying any of said terms and conditions will be binding on us unless in writing and agreed to by authorized representative of this company.



575 Central Avenue
Johnstown, PA 15902
(814) 535-6766
(814) 539-3617 (Fax)
888-442-7829

October 17, 2022

Stege Sanitary District

RE: Sole Source Letter / GapVax, Inc. / Northern CA

In pursuance to your inquiry, please be advised that WECO Industries, LLC, Vacaville, CA, is the sole authorized supplier of all GapVax, Inc. products in the territory of Northern California, Porterville and every area north of it. All counties in the state of Nevada with the exception of Clark County. This includes all major equipment, spare parts, and service.

WECO Industries LLC contact information is as follows:

WECO Industries LLC
4971 Allison Parkway, Suite A
Vacaville, CA, 95688

Contacts: Tom Johnson,
E-mail: tomjohnson@wecoind.com
Toll Free: 800-677-6661
Local: (707) 446-6661
Fax: 707-446-7933
Website: www.wecoind.com

We appreciate your business and look forward to working with you in the future.

Sincerely,

A handwritten signature in black ink, appearing to read "Matt Cooper". The signature is fluid and cursive, with the first name "Matt" and last name "Cooper" clearly distinguishable.

Matthew Cooper
West Coast Regional Sales Manager
GapVax, Inc.
Phone: 888-442-7829
Fax: 814-535-3617
CC: WECO Industries LLC

Corporate Office:

575 Central Avenue, Johnstown, PA 15902 • Toll-Free 888-442-7829 • Phone (814) 535-6766 • Fax (814) 539-3617

RESOLUTION NO. 2217-1122

RESOLUTION COMMENDING ALAN C. MILLER FOR THE LONG AND
EXTRAORDINARY SERVICE AS A MEMBER OF THE BOARD OF DIRECTORS OF THE
STEGE SANITARY DISTRICT

The Directors of the Stege Sanitary District find and determine as follows:

- A. Alan C. Miller has served as a Director of the Stege Sanitary District for over thirty-seven years, longer than any other Director in the nearly 110-year history of the Stege Sanitary District.
- B. Alan C. Miller's over thirty-seven years of service has been exemplary, his actions always going beyond the ordinary effort expected of a Director.
- C. Alan C. Miller has attended numerous California Association of Sanitation Agencies (CASA) meetings, both imparting to CASA the insights learned at the District and bringing back to the District information from such CASA meetings.
- D. Alan C. Miller has represented the District at the Contra Costa Chapter of the California Special Districts Association (CSDA) for many years, furthering the effectiveness of the organization.
- E. Alan C. Miller has regularly attended El Cerrito City Council meetings, representing the District's concerns, and bringing back to the District Board important information about City concerns and activities.
- F. Alan C. Miller spearheaded the preparation of a book about the history of the Stege Sanitary District, *Where the Sewage Meets the Sea*, collaborating with historian David Weinstein in order to document the first hundred years of the Stege Sanitary District.
- G. Alan C. Miller participated in discussions regarding dissolution of the District, voted to instead contract out operations of the District, then finally working to create the safe, efficient, and economical full service wastewater collection system that the District is today.
- H. The District received tremendous benefit from his talent, expertise, and devotion to public service throughout his thirty-seven year tenure in office.

In consideration of the foregoing findings and determinations, it is resolved:

The Directors of the Stege Sanitary District hereby recognize, commend, and declare its appreciation and undying gratitude to Alan C. Miller for his over thirty-seven years of extraordinarily distinguished and exemplary public service as a Member of the Board of Directors of the Stege Sanitary District, thank him most warmly and sincerely for his service, extend to him the very best wishes for the future, and designate November 10th, 2022, Al Miller Appreciation Day.

* * * * *

STATE OF CALIFORNIA)
COUNTY OF CONTRA COSTA)

I HEREBY CERTIFY that the foregoing Resolution was duly and regularly adopted by the Board of Directors of the Stege Sanitary District, at a regular meeting thereof, held on the 10th day of November 2022 by a X-X vote as follows:

AYES: BOARD MEMBERS:
NOES: BOARD MEMBERS:
ABSENT: BOARD MEMBERS:
ABSTAIN: BOARD MEMBERS:

DWIGHT MERRILL, President
Stege Sanitary District
Contra Costa County, California

ATTEST:

REX DELIZO, Secretary
Stege Sanitary District

**CONSIDERATION OF RELOCATION OF SANITARY SEWER MAIN –
1755 EASTSHORE BLVD., EL CERRITO, CA 94530**

ISSUE:

Bellecci and Associates is developing the former OSH parcel into an affordable housing complex and requesting permission to relocate the sanitary sewer main onto Eastshore Blvd. right-of-way at no expense to the District.

FISCAL IMPACT:

The developer is willing to relocate the proposed sanitary sewer main at no cost to the District.

STRATEGIC PLAN:

GOAL 2: Maintain and Improve Infrastructure

WORK PLAN ITEM “b”: Update and implement sewer system master plan to prioritize sewer replacement, funding, and maintain a sewer system life cycle of 60+ years by June 2020 and at least every two (2) years thereafter.

BACKGROUND:

Bellecci and Associates is developing the former OSH parcel into an affordable housing complex. There is an existing 8” HDPE sanitary sewer main located within an easement along an existing planter strip. This existing sanitary sewer main is under a proposed new building location. Bellecci is requesting permission to relocate the sanitary sewer onto Eastshore Blvd. right-of-way at no expense to the District.

The existing 8” HDPE sanitary sewer main was pipe-burst in 2017 by the District Contractor. There will be no improvement in pipe material nor any ease of maintenance for the relocated sanitary sewer main. The District is requesting that Bellecci install a new 8” HDPE pipe within a cast iron pipe since the new line is to be installed using open trench method.

RECOMMENDATION:

Approve Bellecci and Associate’s request to relocate the existing sanitary sewer main and abandon the existing sanitary sewer easement.

ALTERNATIVES:

1. Reject the request.
2. Take no action and provide staff further direction.

ATTACHMENTS:

- Bellecci and Assoc. Request Letter
- Relocation improvement site plan
- Sewer Vicinity Map

This Page Left Blank Intentionally



November 3, 2022

Stege Board of Directors
7500 Schmidt Lane
El Cerrito, CA 94530

Re: Request for Sanitary Sewer Main Relocation

To Whom it May Concern,

Bellecci is the civil engineering team working with AMG & Associates on the El Cerrito Apartments residential project located at 1755 Eastshore Blvd. in El Cerrito (Site)—constrained by Highway 80 along the west side, Eastshore Blvd. along the east side, and Peerless Ave. to the north. The project is developing the former OSH parking lot into an affordable housing complex—consisting of a 219,600 SF, 5-story, podium building providing 310 affordable housing units with at-grade parking below. Due to the constrained nature of this site, the building sits 0'-0" from the property line.

This is a unique project, as it not only adds a significant amount of housing to help alleviate the current housing crisis, but it is doing so by implementing numerous strategies to decrease contaminants in stormwater runoff—such as, removing the open-air on-site parking, encouraging bicycle and multi-modal transit use (qualifies as a transit-oriented development), and implementing stormwater control measures to treat and remove toxins from all runoff before it leaves the Site. Additionally, by *repurposing* the existing on-site building, there will be a reduction in construction contaminants and debris.

According to our records obtained from Stege in December 2020, there is an existing 8" sanitary sewer main situated right below the same property line where the building is proposed. However, according to the Preliminary Title report, a maintenance easement has not been recorded for the sewer main. Meaning, Stege is currently required to request trespassing rights from the owner if any excavation is required to maintain the existing sewer main.

The City has approved plans for their Del Norte Green Streets Improvement Project. This project proposes a bioretention facility running parallel to the existing sanitary sewer main within the shoulder of Eastshore Blvd. As such, the relocated sewer main needs to move an additional 24 feet to the east (towards the center line of Eastshore Blvd.) We are proposing a one-foot separation between the outside face of curb for the bioretention facility and the edge of pipe of the relocated sewer main. This location also avoids other proposed planters near the Eastshore Blvd. and Peerless Ave. intersections to the north.

We are kindly requesting the Stege Board of Directors review and accept our proposal to relocated 688 LF of the 8" SS main approximately 24 feet east into Eastshore Blvd, as depicted on our Proposed Utility Plan. Relocation of the existing 8" sewer main allows for future maintenance and development by Stege without the need to receive authorization from the property owner prior to commencement of work. We would also like to gently point out that an easement would not be

Concord Office:

2290 Diamond Blvd., Suite 100
Concord, CA 94520

925 • 685 • 4569
bellecci.com

Pleasanton Office:

7077 Koll Center Pkwy., Suite 210
Pleasanton, CA 94566

needed to proceed with construction of the affordable housing complex, as the developer can add deep footings (approximately 9' below grade) to avoid the existing sewer main. We understand this is a large undertaking and are happy to work alongside of you to smoothly expedite this process. The Developer is willing to relocate the proposed 688 LF of 8" sanitary sewer main at no cost to Stege Sanitary District.

Thank you for your time and consideration in this matter,



Alexandra Farros-Hoepfner, PE
Associate, Project Manager

Enclosure: Proposed Utility Plan

Concord Office:

2290 Diamond Blvd., Suite 100
Concord, CA 94520

925 • 685 • 4569
bellecci.com

Pleasanton Office:

7077 Koll Center Pkwy., Suite 210
Pleasanton, CA 94566

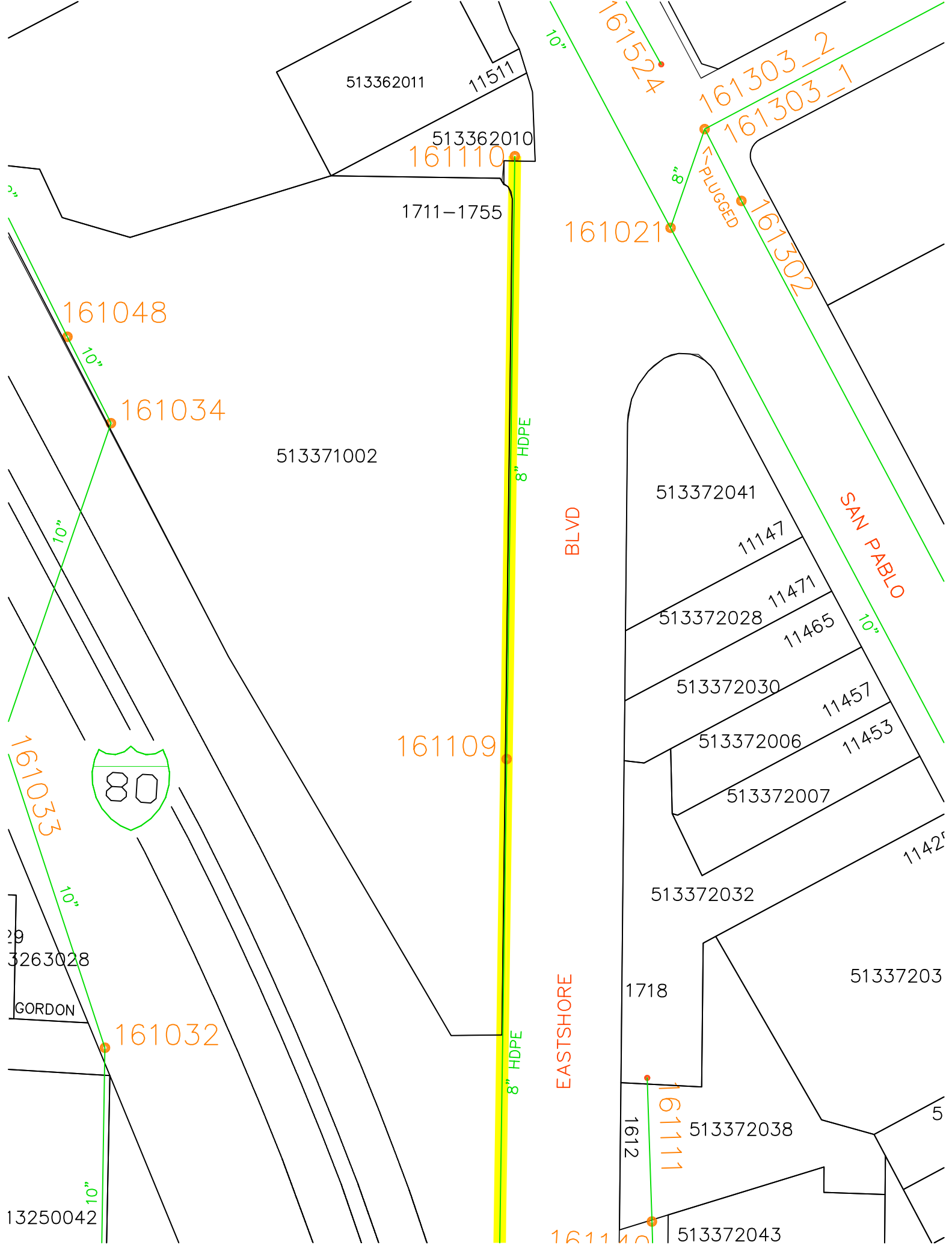

513362011

11511

513362010

1711-1755

161048

161034

513371002

8" HDPE

BLVD

513372041

11147

513372028

11471

11465

513372030

11457

513372006

11453

513372007

1142r

513372032

1718

51337203

3263028

GORDON

161032

8" HDPE

EASTSHORE

1612

161111

513372038

5

13250042

161110

513372043

161303_2
161303_1

8"
PLUGGED

161302



2017 Pipe Burst by District Contractor

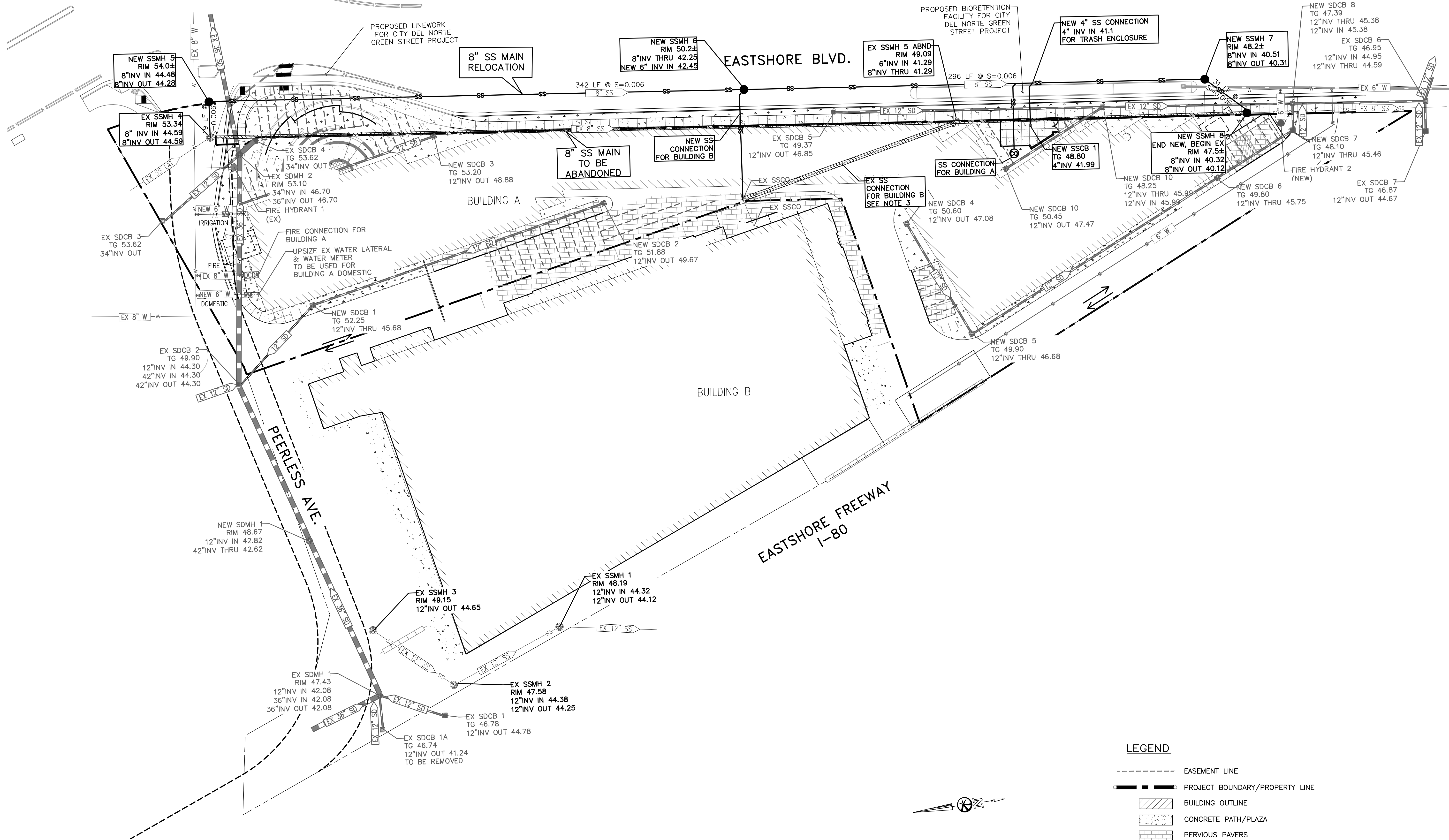

PRELIMINARY
NOT FOR CONSTRUCTION

NOTE:
 1. UTILITIES TO BE CONSTRUCTED PER CITY STANDARDS.
 2. WATER LINES ARE PROPOSED. FINAL DESIGN PER EBMUD.
 3. CONTRACTOR TO IDENTIFY 6" LATERAL IN FIELD AND ABANDON. TO BE RE-ALIGNED TO CONNECT TO NEW SEWER ALIGNMENT
 4. OPEN TRENCH CONSTRUCTION: USE DOUBLE WALLED PIPE, SDR-17 HDPE INSIDE CAST IRON SLEEVE.

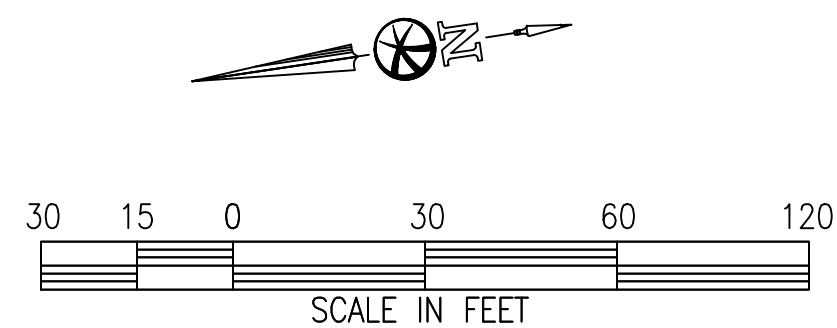

LEGEND

- EASEMENT LINE
- PROJECT BOUNDARY/PROPERTY LINE
- BUILDING OUTLINE
- CONCRETE PATH/PLAZA
- PERVIOUS PAVERS
- LANDSCAPE/TURF
- BIORETENTION FACILITY/FLOW-THROUGH PLANTER
- STORM DRAIN MANHOLE
- STORM DRAIN INLET
- STORM DRAIN
- SANITARY SEWER
- WATER LINE
- ABANDON EX

SHEET	1	OF	1	JOB NO.	21067
	EL CERRITO APARTMENTS		1755 EASTSHORE, LLC		CONTRA COSTA COUNTY
SANITARY SEWER EXHIBIT					
EL CERRITO		CONTRA COSTA COUNTY		CALIFORNIA	
Bellecci		Intelligent Infrastructure		bellecci.com	
925 • 685 • 4569		REVISIONS			
		DATE			
		BY			

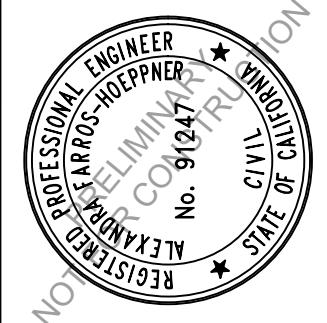

STEGE SANITARY DISTRICT

Operating Statement

11/07/2022

October 2022

33.97% of Fiscal year Completed

	July-October 2022	Annual Budget	% of Annual Budget
Income			
31 - OPERATING REVENUE			
31010 - Sewer Service Charges	(42,669)	3,209,000	-1%
31020 - Permit & Insp. Fees	4,796	12,000	40%
31030 - Connection Fees	26,222	50,000	52%
31040 - San Pablo Impact Fee	16,301	50,000	33%
31080 - Contracted Services	-	33,000	0%
31010a - Capital Service Charges	-	3,775,000	0%
Total 31 - OPERATING REVENUE	4,650	7,129,000	0%
32 - NON-OPERATING REVENUE			
32050 - Interest - 3418	-	15,000	0%
32052 - Interest - 3423	-	5,000	0%
32080 - Property Taxes	-	500,000	0%
32085 - Insurance Dividend	-	-	0%
32090 - Miscellaneous	-	21,000	0%
Total 32 - NON-OPERATING REVENUE	-	541,000	0%
Transfer (to)/from Reserves	-	(109,643)	0%
Total Income	4,650	7,560,357	0%
Expense			
OPERATING EXPENSES			
Administration/General			
45-010 - Salaries & Wages	82,040	255,300	32%
45-020 - Employee Benefits	92,038	141,506	65%
45-029 - Retiree Health	3,823	13,600	28%
45-030 - Directors Expenses	7,430	41,007	18%
45-070 - Insurance	95,841	250,400	38%
Administration - Other	54,015	291,000	19%
Total Administration	335,188	992,813	34%
Maintenance/Engineering			
41-010 - Salaries & Wages	401,228	1,260,660	32%
41-020 - Employee Benefits	193,448	521,701	37%
41-029 - Retiree Health	3,704	15,556	24%
41-100 - Operating Supplies	518	40,000	1%
41-110 - Contractual Services	10,010	101,300	10%
41-207 - Contracted Repairs	21,880	70,000	31%
Maintenance- Other	109,711	286,257	38%
Total Maintenance/Engineering	740,499	2,295,474	32%
Pump Stations	9,216	40,020	23%
Total OPERATING EXPENSES	1,084,903	3,328,307	33%
CAPITAL			
41-650 - Debt Repayment (SRF Loans)	-	43,900	0%
Construction Projects	-	3,833,150	0%
Outlay(Maintenance/Engineering)	178,220	355,000	50%
Total CAPITAL	178,220	4,232,050	4%
Total Expense	1,263,123	7,560,357	17%
Net	(1,258,473)	0	

STEGE SANITARY DISTRICT
Investment, Cash & Receivables Report

11:41:48 AM
 11/07/2022

As of October 31, 2022

	<u>October 31, 2022</u>	<u>September 30, 2022</u>	<u>\$ Change</u>	<u>Deposits</u>	<u>Checks</u>	<u>Transfers</u>
ASSETS						
Current Assets						
Checking/Savings						
LAIF Investment Accts						
11012 - Sewer Operations- 3418	6,079,464	6,354,464	-275,000	0	0	-275,000
11014 - System Rehab- 3423	1,015,783	1,015,783	0	0	0	0
Total LAIF Investment Accts	<u>7,095,247</u>	<u>7,370,247</u>	<u>-275,000</u>	<u>0</u>	<u>0</u>	<u>-275,000</u>
Checking Accts						
100 - Mechanics Bank	3,187	45,533	-42,346	2,061	-319,407	275,000
100 - County Cash Acct #3418	7,695	-8,782	16,477 *	0 *	0	0
Total Checking Accts	<u>10,882</u>	<u>36,751</u>	<u>-25,869</u>	<u>2,061</u>	<u>-319,407</u>	<u>275,000</u>
11021 - Petty Cash	250	250	0	0	0	0
Total Checking/Savings	<u>7,106,379</u>	<u>7,407,247</u>	<u>-300,869</u>	<u>2,061</u>	<u>-319,407</u>	<u>0</u>
301 - Ca Employer's Retiree Benefit Trust	238,670	295,814	-57,144	0	0	0
Total CA Employer's Retiree Benefit Trust	<u>238,670</u>	<u>295,814</u>	<u>-57,144</u>	<u>0</u>	<u>0</u>	<u>0</u>
Accounts Receivable						
11072 - Accounts Receivable	111,533	111,533	0			
Total Accounts Receivable	<u>111,533</u>	<u>111,533</u>	<u>0</u>			

Note: * Reduction or Increase is based on property tax estimate.

I hereby certify that the invested funds of the Stege Sanitary District are in compliance with the investment policies of the Stege Sanitary District and provide sufficient liquidity to meet budgeted expenses for the next six month period.

 Rex Delizo, District Manager

 Date

11:03 AM	STEGE SANITARY DISTRICT			
11/07/2022	Check Report			
Accrual Basis	November 10, 2022			
	Name	Memo	Amount	Num
Nov 10, 22				
	ARAMARK	Hats	-247.60	27894
	Aramark Uniform Services	Uniform Services	-628.57	27895
	Ditch Witch West	Camera Repair	-177.96	27896
	East Bay Sanitary Co., Inc.	Garbage Nov-Dec 2022	-839.98	27897
	EBMUD 39830388387	Hydrant Meter	-1,477.88	27898
	EBMUD 92526846174	Hydrant Meter	-576.48	27899
	ENR	Subscription Renewal	-60.00	27900
	Meyers Nave	Legal Services	-4,177.68	27901
	Nakano Landscape	Landscaping Oct 2022	-290.00	27902
	Pastime Hardware	Maintenance Supplies	-2.87	27903
	PG&E- #0103467151-9	Burlingame Pump Station	-21.16	27904
	PG&E- #6675831511-4	Office/Shop	-963.88	27905
	S.P. Automotive	Maintenance Supplies	-109.41	27906
	TelePacific Communications	Office Phones	-1,157.61	27907
	Thomas & Associates	Generator	-88,686.87	27908
	Universal Building Services	Janitorial Service Oct	-423.00	27909
	WECO Industries, Inc.	Hose Swivel & Fiberglass Poles	-1,668.66	27910
	Wex Bank	Chevron Gas	-79.73	27911
	Xerox Financial Services	Copier Lease Payment 10/03-11/02	-287.51	27912
Nov 10, 22			-101,876.85	

STEGE SANITARY DISTRICT

BOARD OF DIRECTORS MEETING AGENDA CALENDAR

JULY 2022	AUGUST 2022	SEPTEMBER 2022	OCTOBER 2022	NOVEMBER 2022	DECEMBER 2022
7/4 HOLIDAY 4 th of July Fair Booth	CASA Annual Conf. Aug 10-12, Squaw Creek CSDA Annual Conf. Aug 22-25, Palm Springs	9/5 HOLIDAY Board Training AB 1234 (even years) AB 1661 (odd years)		11/24-25 HOLIDAY	12/8 HOLIDAY LUNCHEON 12/26 HOLIDAY
7/7/2022 – 7:00 P.M.	8/18/2022 – 7:00 P.M.	9/1/2022 – 7:00 P.M.	10/6/2022 – 7:00 P.M.	11/10/2022 – 7:00 P.M.	12/8/2022 – 2:00 P.M.
<ul style="list-style-type: none"> • July 4th Fair Debrief • CASA/CSDA Conf. • Diversity, Equity, and Inclusion 	<ul style="list-style-type: none"> • Select Actuary for Analysis of Retiree Health Benefits (odd years) • Quarterly (FY End) Financial Statements • Conn. Charge Report per Gov. Code 66013 • CASA/CSDA Conf. 	<ul style="list-style-type: none"> • CASA/CSDA Conf. Attendee Reports • Diversity, Equity, and Inclusion 	<ul style="list-style-type: none"> • Regional PSL Program Update • Regional FOG Program Update 	<ul style="list-style-type: none"> • Proposed Meeting Calendar • Board Officer Succession Plan • CASA Conference • Diversity, Equity, and Inclusion 	<p><u>2PM MEETING TIME</u></p> <ul style="list-style-type: none"> • Fiscal Year Financial Audit • Resolution Certifying Election Results (even years) • Connection Charge Review • Emergency Contact Update • Meeting Calendar • Consent Decree Quarterly Report • CASA Conference • Pension + OPEB UAL Reports • Nomination & Election of Officers
7/21/2022 – 7:00 P.M.		9/15/2022 – 7:00 P.M.	10/20/2022 – 7:00 P.M.		
<ul style="list-style-type: none"> • CLOSED SESSION <ul style="list-style-type: none"> – Quarterly Claims Rpt • Hearing +Res./Ord. <ul style="list-style-type: none"> – Establish and Collect Sewer Service Charges – Director Meeting Compensation • Resolution Filing Notice of Completion • District Investment Policy • Reimb. Report per Gov. Code 53065.5 • Quarterly Financial Statements • Candidate filing period (even years) • SPASPA Status Report • CASA/CSDA Conf. • Form 470 		<ul style="list-style-type: none"> • Health Care Benefits Review • Consent Decree Quarterly Report 	<ul style="list-style-type: none"> • CLOSED SESSION <ul style="list-style-type: none"> – Quarterly Claims Rpt – Manager Perf. Eval. • SPASPA Status Report • Quarterly Financial Statements 		

STEGE SANITARY DISTRICT BOARD OF DIRECTORS MEETING AGENDA CALENDAR

JANUARY 2023	FEBRUARY 2023	MARCH 2023	APRIL 2023	MAY 2023	JUNE 2023
1/2 & 1/16 HOLIDAY CASA Winter Conf. Jan 25-27, Palm Springs	2/20 HOLIDAY CASA Policy Forum Feb 27-Mar. 1, Wash, DC			5/29 HOLIDAY	6/19 HOLIDAY 6/7 Safety Awards Luncheon
1/19/2023 – 7:00 P.M.	2/2/2023 – 7:00 P.M.	3/4/2023 – 9:00 A.M.	4/6/2023 – 7:00 P.M.	5/4/2023 – 7:00 P.M.	6/1/2023 – 7:00 P.M.
<ul style="list-style-type: none"> • Board Governance Manual Review • Service Rate Discussion • Long Range Planning Workshop Agenda • Director’s Contact Info • Board Training Summ. • CASA Conference • Quarterly Financial Statements • Form 700 • CLOSED SESSION – Quarterly Claims Rpt – Manager Perf. Eval. 	<ul style="list-style-type: none"> • Actuarial Analysis of Retiree Health Benefits Report (even years) • Performance Report (even years) • District of Distinction (even years) • Service Rate Discussion • Long Range Planning Workshop Agenda • Board Training Summ. • CASA Conference • CASA Conference Attendee Reports 	<p><u>9AM MEETING TIME</u></p> <ul style="list-style-type: none"> • Long Range Planning Workshop – Past 5 yrs. Expenditures Review – Self-Assessment of Governance – Strategic Plan Review 	<ul style="list-style-type: none"> • Service Rate Discussion/ Approval (& 30-day Notice) • Board Training Summ. 	<ul style="list-style-type: none"> • Appoint Labor Negot. • Draft Budget • Board Training Summ. • July 4th Fair Discussion • Review of Comparable Agencies • CLOSED SESSION – Conf. Labor Negot. 	<ul style="list-style-type: none"> • Draft Budget • Review Directors’ Meeting Compensation • District Working Capital and Reserve Policy • Approve Project Plans and Specs (+CEQA) • July 4th Fair Discussion • CASA Conference
	2/16/2023 – 7:00 P.M.	3/16/2023 – 7:00 P.M.	4/20/2023 – 7:00 P.M.	5/18/2023 – 7:00 P.M.	6/15/2023 – 7:00 P.M.
	<ul style="list-style-type: none"> • Board Governance Manual Approval • Long Range Planning Workshop Agenda • Service Rate Discussion • SPASPA Status Report 	<ul style="list-style-type: none"> • Auditor – RFP • California Employer’s Retiree Benefit Trust (CERBT) • Service Rate Discussion • Action Plan • Board Training Summ. • Consent Decree Quarterly Report • CASA Conference Attendee Reports • Form 700 	<ul style="list-style-type: none"> • Draft Budget • Employee Benefit Package Review • Service Rate Discussion/Approval (+ 30-day Notice) • July 4th Fair Discussion • Quarterly Financial Statements • SPASPA Status Report • CLOSED SESSION – Quarterly Claims Rpt 	<ul style="list-style-type: none"> • Resolution Ordering Board Election (even years) • Draft Budget • July 4th Fair Discussion • Service Rate Discussion/Approval (+ 30-day Notice) • CLOSED SESSION – Manager Perf. Eval. – Conf. Labor Negot. 	<ul style="list-style-type: none"> • Resolution Salary of District Manager • Resolution Employee Salary Ranges • Resolution Approve/Adopt Budget • Review and Approve Incentive Award • Adopt Incentive Award Goals & Objectives • July 4th Fair Discussion • CD Quarterly Report • CASA Conference • CLOSED SESSION – Counsel Perf. Eval.